

AGENDA FOR A WORKSHOP MEETING OF THE BOARD OF DIRECTORS
OF THE VALLECITOS WATER DISTRICT
WEDNESDAY, MAY 24, 2017, AT 5:00 P.M.
AT THE DISTRICT OFFICE
201 VALLECITOS DE ORO, SAN MARCOS, CALIFORNIA

CALL TO ORDER – PRESIDENT ELITHARP

PLEDGE OF ALLEGIANCE

ROLL CALL

In the case of an emergency, items may be added to the Agenda by a majority vote of the Board of Directors. An emergency is defined as a work stoppage; a crippling disaster; or other activity which severely imperils public health, safety, or both. Also, items which arise after the posting of the Agenda may be added by a two-thirds vote of the Board of Directors.

ADOPT AGENDA FOR THE WORKSHOP MEETING OF MAY 24, 2017

PUBLIC COMMENT

Persons wishing to address a matter not on the Agenda may be heard at this time; however, no action will be taken until the matter is placed on a future agenda in accordance with Board policy. Public comments are limited to three minutes. A Request to Speak form is required to be submitted to the Executive Secretary prior to the start of the meeting, if possible. Public comment should start by stating name, address and topic. The Board is not permitted during this time to enter into a dialogue with the speaker.

ITEMS FOR DISCUSSION

1. BUDGET AND RATES REVIEW AND UPDATE (pp. 3-121)

*******END OF DISCUSSION ITEMS*******

OTHER BUSINESS

*******END OF OTHER BUSINESS*******

*******END OF AGENDA*******

If you have any disability which would require accommodation in order to enable you to participate in this meeting, please call the Executive Secretary at 760.744.0460 ext. 264 at least 48 hours prior to the meeting.

Audio and video recordings of all Board meetings are available to the public at the District website www.vwd.org

AFFIDAVIT OF POSTING

I, Diane Posvar, Executive Secretary of the Vallecitos Water District, hereby certify that I caused the posting of this Agenda in the outside display case at the District office, 201 Vallecitos de Oro, San Marcos, California by 5:00 p.m., Thursday, May 18, 2017.

Diane Posvar



Proposed Budget
Fiscal Year
2017-2018

Sustainability

A guiding influence for everything we do

This page intentionally left blank

Our Mission

Water and wastewater specialists providing exceptional and sustainable services.

This mission of exceptional and sustainable services is reflected in this budget and in the attitudes and commitment of the Vallecitos Water District staff and Board Members.



Clockwise: James Hernandez, Craig Elitharp (center), Hal Martin, Betty Evans and Mike Sannella

Board of Directors

Craig Elitharp, President
James Hernandez, Vice President
Hal Martin
Betty Evans
Mike Sannella

Vallecitos Water District is a public agency organized in 1955, proudly serving the City of San Marcos, portions of Escondido, Carlsbad and the surrounding unincorporated areas.

This page intentionally left blank

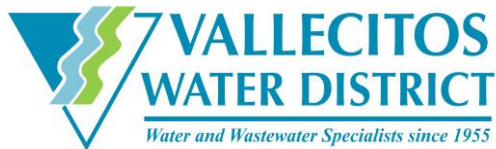

201 Vallecitos de Oro · San Marcos, California · 92069-1453 · (760) 744-0460

Date: May 24, 2017
To: Honorable Board of Directors
Regarding: Fiscal Year 2017/18 Proposed Budget

Enclosed is the **Proposed Budget** for Fiscal Year 2017/18. The budget totals \$75.2 million compared to \$68.5 million for the 2016/17 budget and is comprised of \$53.2 million of operational expenses (a 7.2% increase from the \$49.6 million in 2016/17 operating budget) and a commitment of \$15.8 million for capital items and projects (\$13.3 million in 2016/17).

The operational increase of \$3.6 million is attributable to a projected \$2.5 million increase in cost of water purchases as the District moves further from the drought and purchases more water. The remaining \$1.1 million is mainly from increases resulting from transmission and distribution (main line breaks), general and administrative costs and information technology. In addition, \$7.4 million from operations is being set aside for capital replacement.

Rate increases contained in this budget for Water, Sewer and Ready-to-Serve are part of an ongoing cost of service study. The rates are to recover the costs of service and meet strategic and financial objectives of the budget.

Long-range Financial Planning

As with recent budgets, this budget includes a 10-year projection of operating costs and capital needs in order to plan for a sound future in water supply and reliability. Fiscal sustainability is absolutely a necessary factor in the equation for future reliability and is a guiding influence in everything the District does.

All District employees are responsible to consider costs involved with activities and try to work as efficiently and effectively as possible. Consideration of controlling costs translates into the future viability of the District. Some of these considerations are: rate affordability; maintaining reserves, assess adequacy to cover debt obligations now and in the future; and a credit worthy cash position. We plan to meet our capital needs and maintain a strong financial position without incurring any new debt.

FINANCIAL HIGHLIGHTS

The following narratives are financial highlights and comparisons of this budget, FY 2017/18, and last budget; FY 2016/17.

Water Operations (pages 3-14)

Water purchases are projected to total 14,576 acre feet with sales of 13,760 acre feet for 2017/18. The water operating budget increased by \$0.6 million from last year's budget, excluding water costs. With water costs, the budget increased \$3.1 million, or 8.4%.

Board of Directors

May 24, 2017

Page Two

Wastewater Operations (pages 15-24)

Wastewater operating costs increased \$0.5 million, or 3.9%, over last year's budget due to increases in treatment, personnel, information technology, and outside services. Reclaimed water costs are recovered by contractual sales to the Carlsbad Municipal Water District and Olivenhain Municipal Water District.

Personnel (pages 25-31)

Fiscal year 2017/18 does not add any new positions. Two positions were reclassified and four are eliminated. Salaries and benefits for 2017/18 increased from the last budget year by \$77 thousand or 0.5% due to increasing costs of retirement benefits and longevity of existing employees. Management will continue to scrutinize the need for all positions and only fill positions if absolutely necessary.

Capital Budget (pages 33-95)

Capital projects are summarized on the Comprehensive Project List found on page 34. Details of each project, including timing of phases and spending, are presented on pages 36 through 95, followed by requests for easements, vehicles and equipment of \$818,000. Of the \$122.4 million capital budget, \$57.4 million are new requests and \$22.9 million are for future projects included for planning purposes. The remainder is from projects carried over from the prior year resulting in a capital budget increase of \$3.4 million.

Reserve Budget and Projection (pages 98-104)

The Reserve Budget includes revenues and transfers from various sources and summarizes appropriations and expected cash outflows for debt service and capital projects. Page 99 displays the 2017/18 reserve budget for consideration. Page 100 forward display detailed reserve projections for four subsequent years followed by a summary projection for the five years thereafter.

As a final note, our projections are based on trends, anticipated large one-time expenditures, economic factors within our industry, and global factors influencing our operations. Obviously, a good amount of forethought and monitoring at both the Board and staff levels has been required to produce such a realistic and useable financial guide.

Respectfully submitted,

Glenn Pruum, General Manager

VALLECITOS WATER DISTRICT

BUDGET FOR THE YEAR ENDING JUNE 30, 2018

TABLE OF CONTENTS

Section	Page#
Budgetary Considerations	1
Chart - Overall Budget	2
Operations	3
Water Statistics Graphs	4
Function Definitions - Water Operations	6
Graph - Water Operating Budget	10
Water Operations Budget	11
Water Operations Budget Expense Detail	12
Wastewater Statistics Graphs	15
Function Definitions - Wastewater Operations	18
Chart - Wastewater Operating Budget	20
Wastewater Operations Budget	21
Wastewater Operations Budget Expense Detail	22
Salary and Benefit Recap	25
Organization Chart	26
Personnel Budget	31
Public Awareness & Conservation Programs	32
Capital	33
Master Projects List	34
Capital Improvement Program Detail	36
Vehicles and Equipment Schedule	96
Debt Service	97
Long-Range Planning	98
Reserve Budget	99
Reserve Projections	100
Replacement Reserve Limits	105

This page intentionally left blank

VALLECITOS WATER DISTRICT

BUDGET FOR THE YEAR ENDING JUNE 30, 2018

BUDGETARY CONSIDERATIONS

Mission Statement

Water and wastewater specialists providing exceptional and sustainable services.

The budget reflects the mission statement

Budgetary Approach

Governmental agencies, such as cities and counties, usually approach their budgets from the “revenue end.” Since their revenues are somewhat predictable and restricted, their budgetary considerations are based on setting a level of service (expense total) that can be attained with those available funds.

A special district, however, must make a more thorough analysis. Normally, the expenses can be determined with a high degree of accuracy, and it’s the revenues that must be set to cover those expenses. To complicate matters, factors such as weather variability and customer usage habits can have a profound effect on the overall revenue projection.

Operations vs. Capital Budget

The budget is designed to ensure various revenues and fees are used as intended. The Operations Budget, which covers the ongoing cost of running the District, is paid by the rate payers of the District through charges for water and sewer service. The Capital Facilities Budget is covered primarily by fees on new development and existing customers with increased demands.

Operating revenue in excess of operating expense is earmarked for transfer to the Replacement Reserve Fund for the future replacement of assets. This ensures the current users of our system are paying their fair share for the maintenance of existing facilities as they depreciate.

2017-18 OVERALL BUDGET

\$75,227,000

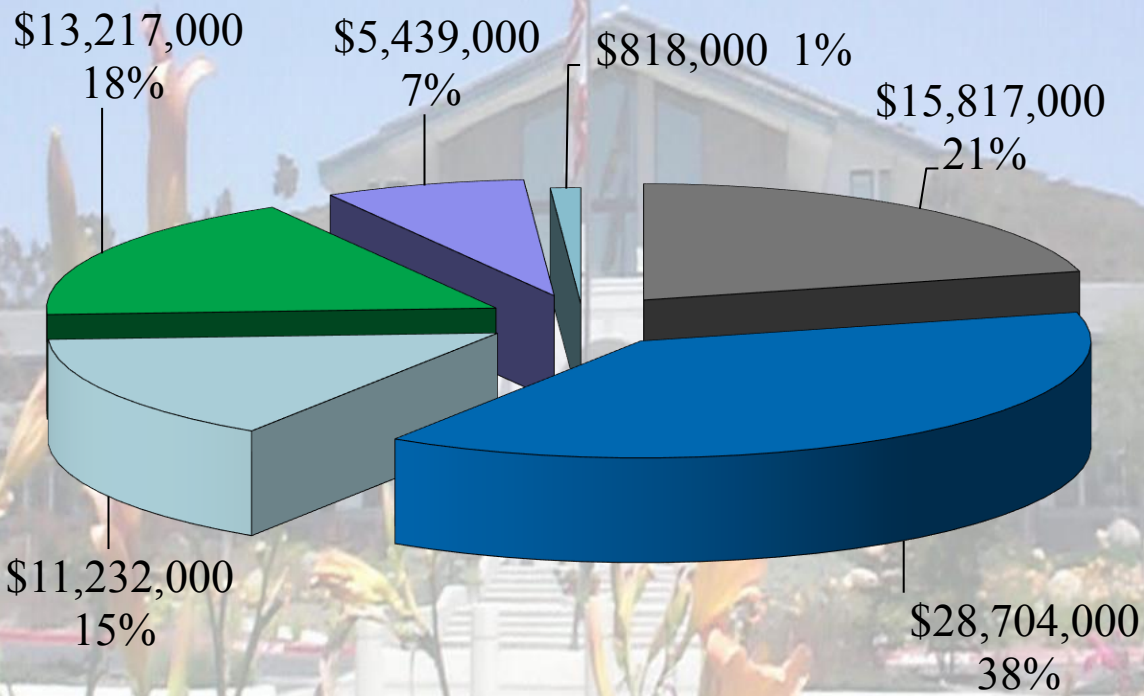

- Capital
- Water Operations
- Debt Service
- Water Purchases
- Wastewater Operations
- Easements, Vehicles & Equipment

2017-18 OPERATING BUDGET
WATER



VALLECITOS WATER DISTRICT

METERS IN SERVICE

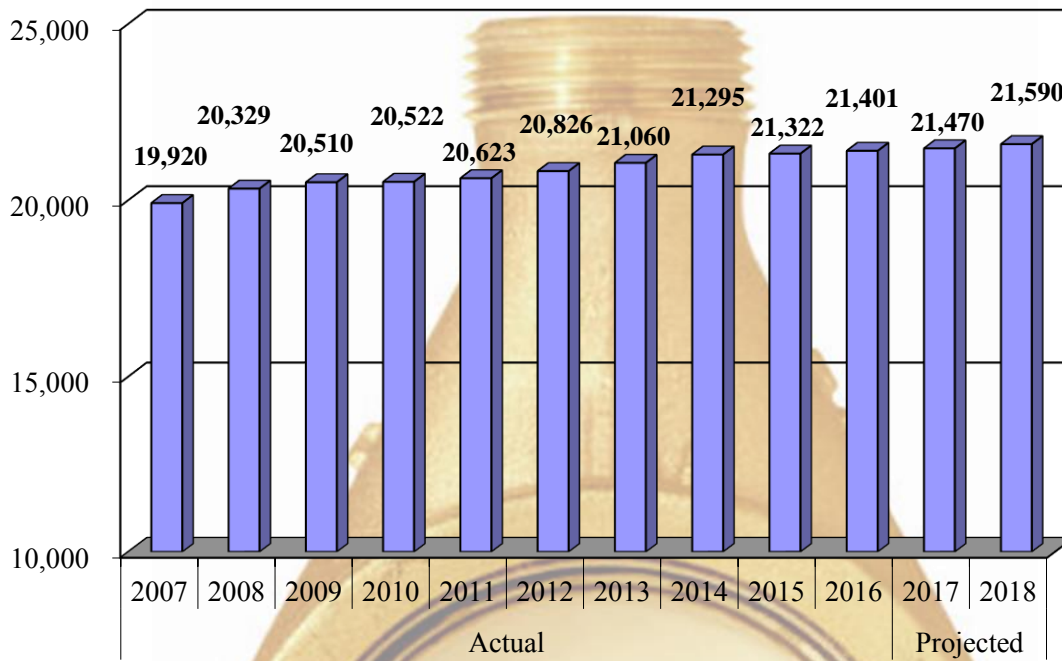

Fiscal Year End June 30

METER ADDITIONS

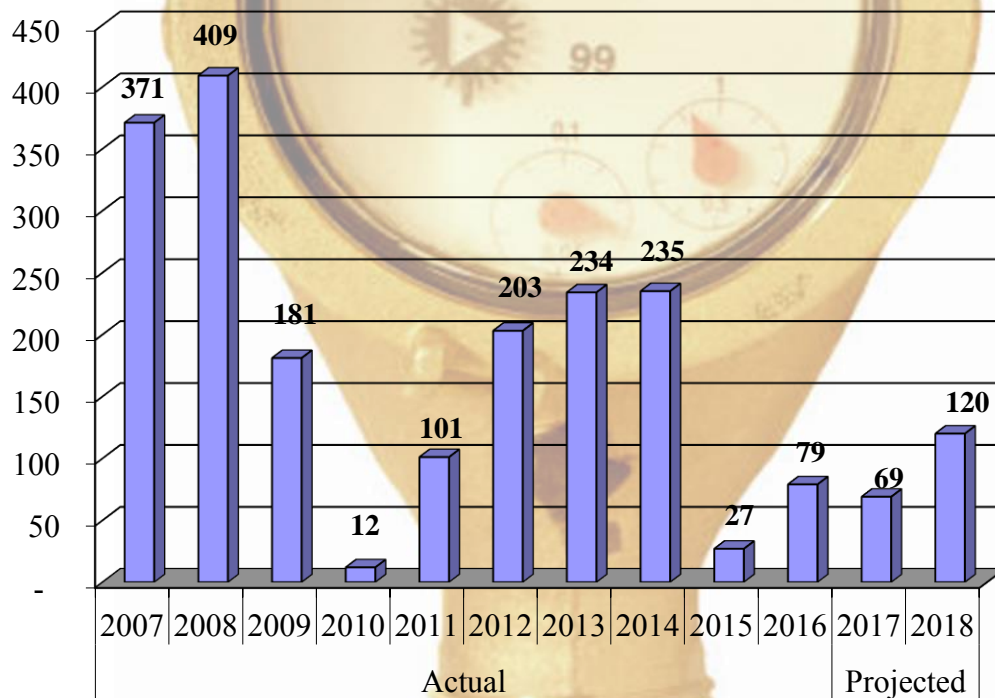

Fiscal Year End June 30

WATER SALES IN ACRE FEET

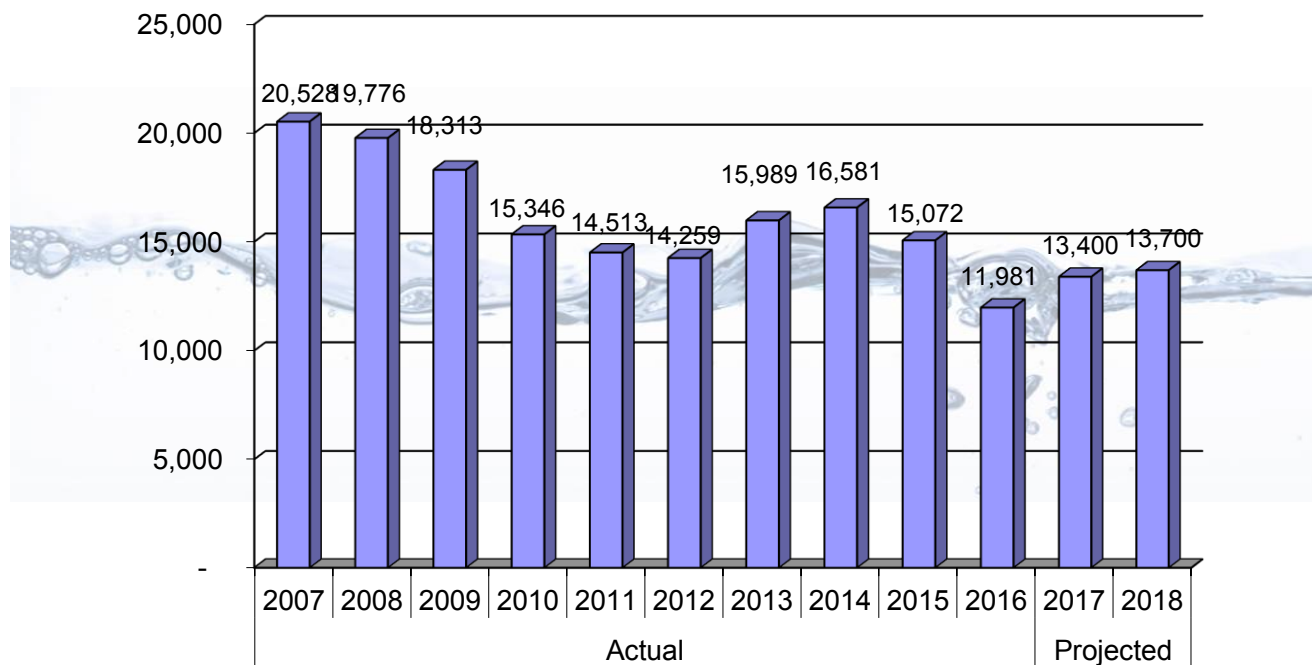

Year End Jun 30

UNBILLED WATER

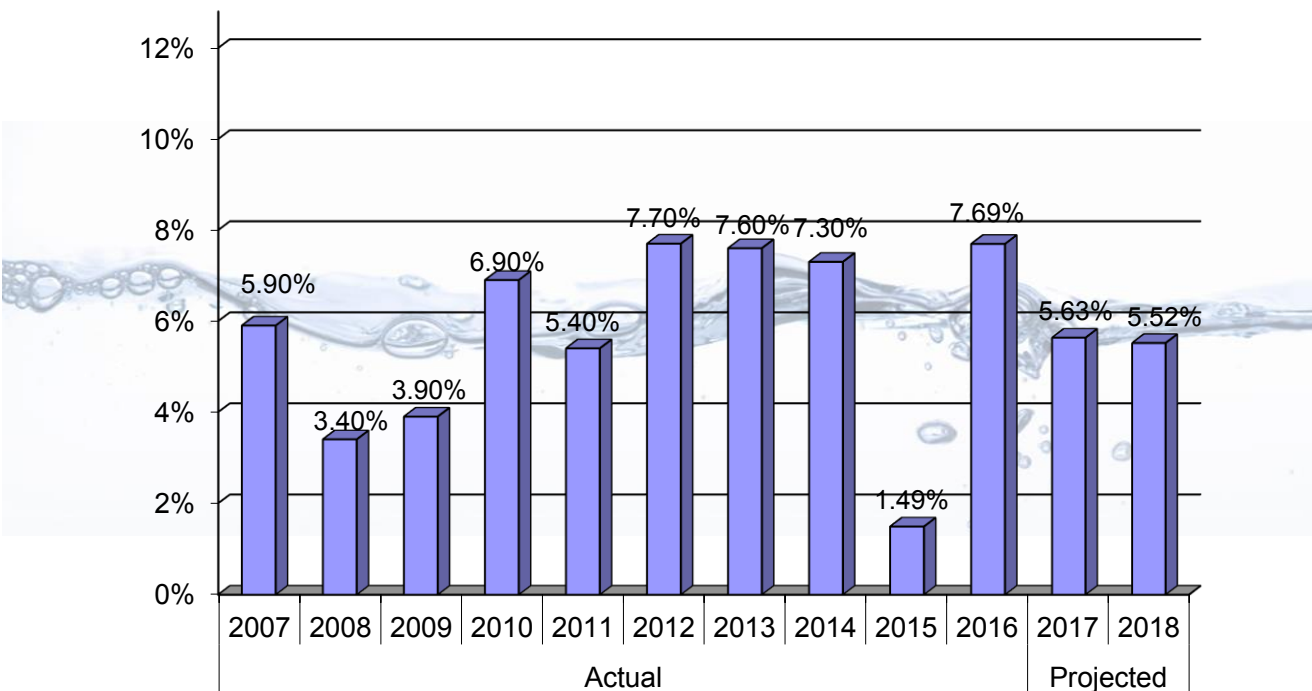

Year End June 30

Unbilled Water includes use acquired with one-day permits, tie-ins, operational use, fire hydrant damage and use, meter malfunctions, leaks and timing differences

VALLECITOS WATER DISTRICT

BUDGET FOR THE YEAR ENDING JUNE 30, 2018

FUNCTION DEFINITIONS - WATER OPERATIONS

REVENUES

Water Sales: Monthly charges to cover the wholesale cost of water, with a minimal markup targeted to cover some operating costs and provide funds for capital improvements and replacement.

Ready To Serve: Monthly charge to cover fixed costs, regardless of water sales. Examples include maintenance of reservoirs and transmission lines, meter reading and administrative costs such as insurance.

Pumping Charges: Charges to customers at high elevations, to cover the power costs required to deliver water.

Interest and Other: Interest revenue, late charges, backflow fees, engineering fees and other miscellaneous revenues.

OPERATING EXPENSES

Water Purchases: Vallecitos purchases its water from two sources: The San Diego County Water Authority (SDCWA) and the Olivenhain Municipal Water District. Desalinated water is included in the water purchased from SDCWA.

Pumping: To move water to various elevations, and to provide adequate pressure and storage to higher service connections. Includes maintenance of ten pump stations, readings, and power costs.

Water Quality: To monitor incoming water in accordance with federal and state regulations. Includes collecting samples and reporting results, and maintenance of monitoring equipment.

Water Treatment: To treat water in tanks, handle chemicals, and use and maintain injection equipment for pipelines.

Tanks and Reservoirs: Maintenance of 17 steel tanks and 2 reservoirs. Includes corrosion control, security, and water level monitoring.

Transmission and Distribution: Maintenance of pipeline system within 45 square miles, consisting of 329 miles of pipes. Includes 26 pressure reducing stations, 3 (internal) flow control facilities, all air releases/blow-offs, fire hydrants (buried portion), cross-tie valves with other districts, and valve exercising.

Services: Maintenance of all service lines located from main lines to meters.

VALLECITOS WATER DISTRICT

BUDGET FOR THE YEAR ENDING JUNE 30, 2018

FUNCTION DEFINITIONS - WATER OPERATIONS (Continued)

Meters: Reading approximately 21,400 meters monthly for billing purposes as well as maintenance of all customer meters.

Backflow Prevention: Ensures compliance with Title 17, requiring backflow devices for specific connections to protect quality of water in our system.

Customer Accounts: Costs related to opening and closing accounts, response to customer concerns, billing costs (statements, mailing), and uncollectible accounts.

Equipment and Vehicles: Maintenance of District equipment. Includes all construction equipment, water, sewer and administrative vehicles, plus miscellaneous tools and equipment.

Buildings and Grounds: Maintenance of administrative and operations buildings, warehouse, and shops. Also includes power costs, alarmed security system, landscape service, janitorial, and pest control.

Engineering: All costs of engineering, capital facilities and inspection services. Includes review and monitoring of development to ensure compliance with standard design practices, impact on existing system and environment, and orderly planning to provide adequate water and sewer service as demand dictates.

Safety and Regulatory Affairs: Program to control unnecessary risks, hazardous conditions, and unsafe practices, and minimize physical losses, personnel injuries, and district liability, and to provide for regulatory compliance in environmental, public health and other mandated areas.

Information Technology: Centralization of the District's technology to maintain hardware, software, servers, networks, and interfaces.

General and Administrative

Cost of Labor:

- *Salaries* include administrative and conservation personnel salaries and all vacation, sick leave, and holiday time for administrative and water personnel.
- *Group Insurance* is health, vision, and dental costs for all administrative and water personnel.
- *Workers' Compensation Insurance* costs for all administrative and water personnel.
- *Public Employees Retirement System (PERS)* participation costs for all administrative and water personnel.
- *Social Security* costs for all administrative and water personnel.

VALLECITOS WATER DISTRICT

BUDGET FOR THE YEAR ENDING JUNE 30, 2018

FUNCTION DEFINITIONS - WATER OPERATIONS (Continued)

General and Administrative (continued)

- *Other Taxes/Benefits* includes unemployment and other miscellaneous employee taxes and benefits such as annual luncheon, picnic, and awards for all personnel.

District Insurance premium costs protect District assets, such as buildings and vehicles, and provide liability coverage for potential claims.

Outside Services are provided by consultants and temporary help.

Legal costs are incurred for general legal counsel (presence at board meetings, contracts, employment issues, etc.)

Auditing is conducted by a certified public accounting firm to provide an opinion on the annual financial report.

Banking Services are provided to maintain the District's general checking account plus trust and custody services.

Office Supplies are purchased for necessary administration of the District including office equipment costing less than the capitalization threshold.

Postage not related to public relations or customer billing includes notifications, such as shutdowns and public hearing notification mailings.

Office Equipment Repair covers maintenance contracts on computer system, billing equipment, copiers, telephone system, and other repairs as needed.

Telephone costs are for service at administration and water operations, long distance, data lines, and cellular phone service for field and key personnel.

Travel costs are for administrative and water personnel.

Meetings and Seminars for administrative and water personnel provide District representation and professional development.

Dues and Subscriptions are for memberships and periodicals to various organizations, such as American Water Works Association (AWWA).

Public Awareness/Conservation is the "image and information" arm of the District, utilizing publications, special events, the speakers' bureau, and the VWD School Program to present Vallecitos as the "Water and Wastewater Specialists" and promote effective water conservation programs.

VALLECITOS WATER DISTRICT

BUDGET FOR THE YEAR ENDING JUNE 30, 2018

FUNCTION DEFINITIONS - WATER OPERATIONS (Continued)

General and Administrative (continued)

Regulatory Fees are incurred for renewal fees for personnel certifications such as water distribution and treatment, notary, and professional memberships, state regulatory agencies, and other compliance matters.

Election and Annexations facilitation costs are assessed by the County.

Director Fees are paid for attendance of board meetings, professional conferences, and other District-sanctioned organizations.

Director Expenses include all costs incurred by Directors, such as travel reimbursement and conference fees.

Other/Mandated Reimbursements include miscellaneous expenses that do not specifically apply to any of the above-referenced categories less mandated cost reimbursements due from the State.

Administrative Credit Transfer is a collection or recovery of overhead costs that are applied to all construction work orders.

2017-18 WATER OPERATING EXPENSE BUDGET
\$39,936,000

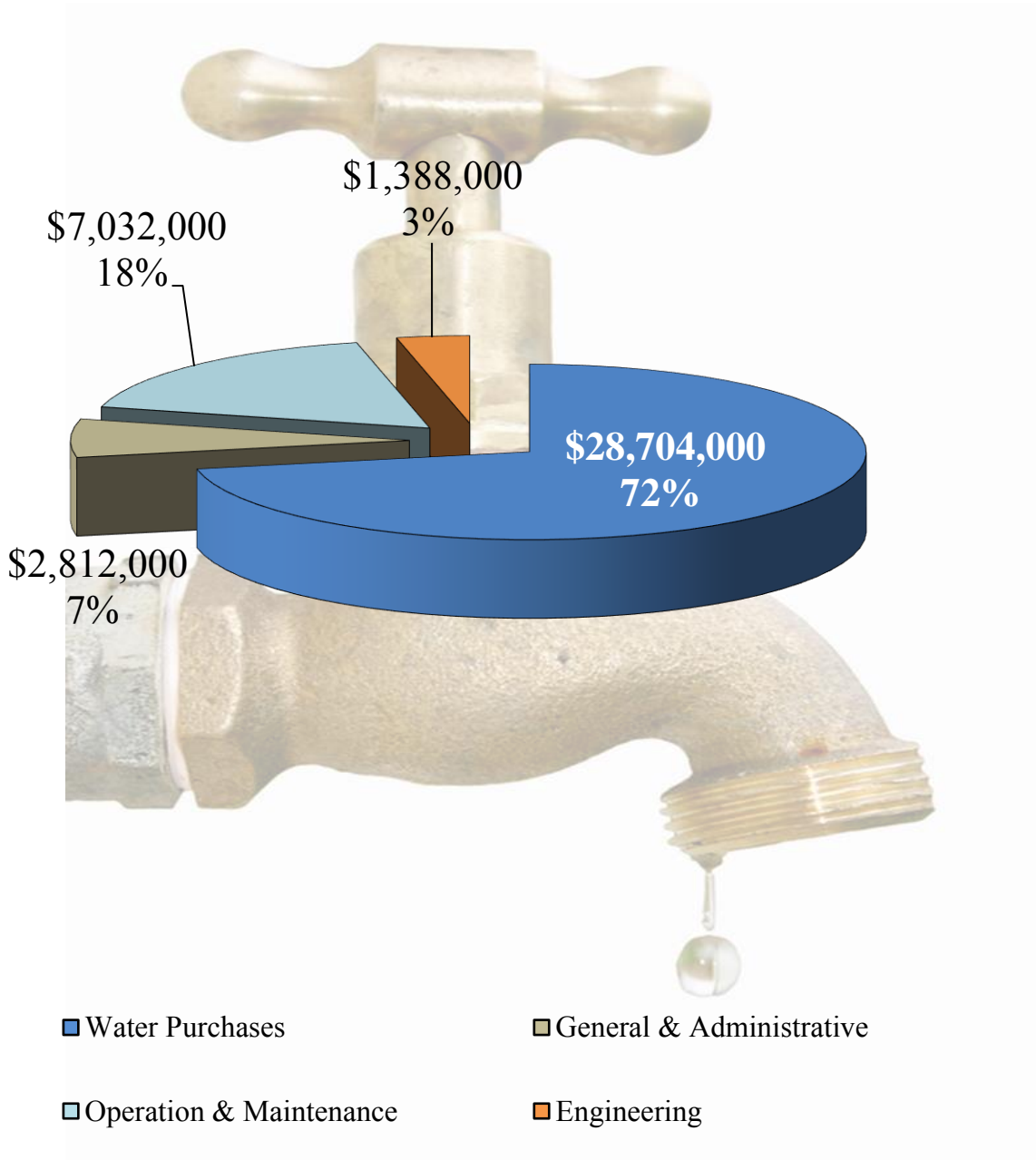

VALLECITOS WATER DISTRICT

WATER OPERATIONS BUDGET FOR THE YEAR ENDING JUNE 30, 2018

		<u>Actual</u>	<u>Budget</u>	<u>Projected</u>	<u>Budget</u>	<u>Estimated</u>
		<u>FY 15-16</u>	<u>FY 16-17</u>	<u>FY 16-17</u>	<u>FY 17-18</u>	<u>FY 18-19</u>
OPERATING REVENUES						
Water Sales	4001	\$18,797,274	\$23,727,000	\$ 21,535,000	\$ 26,800,000	\$ 28,753,000
Ready to Serve	4003	13,602,800	12,244,000	13,724,000	13,229,000	13,952,000
Pumping Charges	4002	138,870	300,000	160,000	250,000	340,000
Interest	4401	174,922	5,000	5,000	5,000	5,000
Other	Various	847,468	580,000	705,000	675,000	694,000
Total Revenue		<u>33,561,334</u>	<u>36,856,000</u>	<u>36,129,000</u>	<u>40,959,000</u>	<u>43,744,000</u>
OPERATING EXPENSES						
Water Purchases	1010	22,190,912	26,270,000	26,500,000	28,704,000	31,242,000
Pumping	2010	531,774	531,000	566,000	677,000	801,000
Water Quality	2020	129,300	165,000	105,000	175,000	187,000
Water Treatment	2030	392,891	375,000	428,000	447,000	474,000
Tanks & Reservoirs	2040	371,156	344,000	292,000	416,000	429,000
Transmission & Dist.	2050	1,189,437	1,412,000	1,794,000	1,835,000	2,048,000
Services	2060	219,408	190,000	153,000	245,000	273,000
Meters	2070	713,164	651,000	611,000	629,000	655,000
Backflow Prevention	2080	60,210	72,000	74,000	64,000	66,000
Customer Accounts	4010	533,906	686,000	549,000	614,000	641,000
Equipment & Vehicles	4210	279,557	317,000	290,000	304,000	301,000
Building & Grounds	4110	351,317	318,000	392,000	362,000	357,000
Engineering	5010	1,270,198	1,539,000	1,317,000	1,388,000	1,443,000
Safety & Reg. Affairs	5210	223,760	272,000	214,000	261,000	272,000
Information Technology	6230	732,457	941,000	786,000	1,003,000	1,046,000
General & Admin.	6xxx	3,455,410	2,773,000	2,913,000	2,812,000	2,979,000
Total Expense		<u>32,644,857</u>	<u>36,856,000</u>	<u>36,984,000</u>	<u>39,936,000</u>	<u>43,214,000</u>
OPERATING INCOME		916,477	-	(855,000)	1,023,000	530,000
LESS TRANSFERS TO REPLACEMENT RESERVE						
		<u>916,477</u>	<u>-</u>	<u>(855,000)</u>	<u>1,023,000</u>	<u>530,000</u>
NET INCOME		<u>\$ -</u>	<u>\$ -</u>	<u>\$ -</u>	<u>\$ -</u>	<u>\$ -</u>

VALLECITOS WATER DISTRICT

WATER OPERATIONS BUDGET FOR THE YEAR ENDING JUNE 30, 2018

		Actual FY 15-16	Budget FY 16-17	Projected FY 16-17	Budget FY 17-18	Estimated FY 18-19
WATER PURCHASES	5001	\$22,190,912	\$26,270,000	\$ 26,500,000	\$ 28,704,000	\$ 30,881,000
PUMPING						
Cost of Labor	2010xxx.51xx	77,021	86,000	84,000	104,000	109,000
Materials & Supplies	" .53xx	39,698	15,000	26,000	30,000	33,000
Outside Repair/Service	" .54xx	22,253	10,000	8,000	18,000	19,000
Power	" .5306	392,802	420,000	448,000	525,000	640,000
Total Pumping		531,774	531,000	566,000	677,000	801,000
WATER QUALITY						
Cost of Labor	2020000.51xx	42,760	89,000	36,000	63,000	66,000
Material & Supplies	" .53xx	34,070	28,000	41,000	50,000	57,000
Outside Repair/Service	" .54xx	52,470	48,000	28,000	62,000	64,000
Total Water Treatment		129,300	165,000	105,000	175,000	187,000
WATER TREATMENT						
Cost of Labor	2030000.51xx	317,946	329,000	368,000	375,000	395,000
Material & Supplies	" .53xx	18,106	37,000	44,000	42,000	47,000
Outside Repair/Service	" .54xx	56,839	9,000	16,000	20,000	22,000
Power	" .5306	-	-	-	10,000	10,000
Total Water Treatment		392,891	375,000	428,000	447,000	474,000
TANKS & RESERVOIRS						
Cost of Labor	2040xxx.51xx	225,456	249,000	204,000	248,000	258,000
Materials & Supplies	" .53xx	28,618	18,000	18,000	25,000	23,000
Outside Repair/Service	" .54xx	112,257	70,000	65,000	138,000	142,000
Power	" .5306	4,825	7,000	5,000	5,000	6,000
Total Tanks & Reservoirs		371,156	344,000	292,000	416,000	429,000
TRANSMISSION & DISTRIBUTION						
Cost of Labor	2050xxx.51xx	929,020	1,074,000	1,137,000	1,178,000	1,244,000
Materials & Supplies	" .53xx	176,447	175,000	141,000	265,000	274,000
Outside Repair	" .54xx	73,608	150,000	506,000	380,000	516,000
Power	" .5306	10,362	13,000	10,000	12,000	14,000
Total Trans. & Dist.		1,189,437	1,412,000	1,794,000	1,835,000	2,048,000
SERVICES						
Cost of Labor	2060xxx.51xx	108,553	120,000	70,000	100,000	107,000
Materials & Supplies	" .53xx	70,813	50,000	17,000	25,000	24,000
Outside Repair	" .54xx	40,042	20,000	66,000	120,000	142,000
Total Services		219,408	190,000	153,000	245,000	273,000

VALLECITOS WATER DISTRICT

WATER OPERATIONS BUDGET FOR THE YEAR ENDING JUNE 30, 2018

		<u>Actual</u> <u>FY 15-16</u>	<u>Budget</u> <u>FY 16-17</u>	<u>Projected</u> <u>FY 16-17</u>	<u>Budget</u> <u>FY 17-18</u>	<u>Estimated</u> <u>FY 18-19</u>
METERS						
Cost of Labor	2070xxx.51xx	\$ 639,288	\$ 595,000	\$ 585,000	\$ 565,000	\$ 599,000
Material & Supplies	" .53xx	69,031	45,000	18,000	53,000	47,000
Outside Service/Repair	" .54xx	4,845	11,000	8,000	11,000	9,000
Total Meters		<u>713,164</u>	<u>651,000</u>	<u>611,000</u>	<u>629,000</u>	<u>655,000</u>
BACKFLOW PREVENTION						
Cost of Labor	2080000.51xx	60,066	70,000	73,000	25,000	27,000
Materials & Supplies	" .53xx	144	2,000	1,000	2,000	2,000
Outside Service	" .54xx	-	-	-	37,000	37,000
Total Backflow		<u>60,210</u>	<u>72,000</u>	<u>74,000</u>	<u>64,000</u>	<u>66,000</u>
CUSTOMER ACCOUNTS						
Cost of Labor	4010000.51xx	406,606	546,000	436,000	487,000	519,000
Materials & Supplies	" .53xx	58,516	55,000	49,000	55,000	50,000
Outside Service/Repair	" .54xx	40,223	45,000	32,000	32,000	38,000
Uncollectible Accts.	" .5703	28,561	40,000	32,000	40,000	34,000
Total Cust. Accts.		<u>533,906</u>	<u>686,000</u>	<u>549,000</u>	<u>614,000</u>	<u>641,000</u>
EQUIPMENT & VEHICLES						
Cost of Labor	4210000.51xx	74,239	132,000	88,000	114,000	118,000
Material & Supplies	" .53xx	66,898	45,000	71,000	65,000	68,000
Fuel	" .5307	96,585	100,000	85,000	95,000	99,000
Outside Repair	" .54xx	41,835	40,000	46,000	30,000	16,000
Total Equip. & Vehicles		<u>279,557</u>	<u>317,000</u>	<u>290,000</u>	<u>304,000</u>	<u>301,000</u>
BUILDING & GROUNDS						
Cost of Labor	4110000.51xx	175,710	153,000	206,000	173,000	163,000
Materials & Supplies	" .53xx	36,373	57,000	22,000	63,000	65,000
Outside Services	" .54xx	71,677	48,000	74,000	76,000	78,000
Power	" .5306	67,557	60,000	90,000	50,000	51,000
Total Bldg. & Grnd.		<u>351,317</u>	<u>318,000</u>	<u>392,000</u>	<u>362,000</u>	<u>357,000</u>
ENGINEERING						
Cost of Labor	5010000.51xx	1,213,380	1,397,000	1,283,000	1,315,000	1,373,000
Materials & Supplies	" .53xx	36,588	21,000	3,000	25,000	21,000
Outside Services	" .54xx	20,230	121,000	31,000	48,000	49,000
Total Engineering		<u>1,270,198</u>	<u>1,539,000</u>	<u>1,317,000</u>	<u>1,388,000</u>	<u>1,443,000</u>

VALLECITOS WATER DISTRICT

WATER OPERATIONS BUDGET FOR THE YEAR ENDING JUNE 30, 2018

		Actual FY 15-16	Budget FY 16-17	Projected FY 16-17	Budget FY 17-18	Estimated FY 18-19
SAFETY & REG. AFFAIRS						
Cost of Labor	5210000.51xx	\$ 196,736	\$ 244,000	\$ 205,000	\$ 234,000	\$ 246,000
Materials & Supplies	" .53xx	16,999	14,000	2,000	14,000	13,000
Safety Support	" .54xx	10,025	14,000	7,000	13,000	13,000
Total Safety		<u>223,760</u>	<u>272,000</u>	<u>214,000</u>	<u>261,000</u>	<u>272,000</u>
INFORMATION TECHNOLOGY						
Cost of Labor	6230000.51xx	376,974	544,000	419,000	523,000	554,000
Materials & Supplies	" .53xx	100,865	104,000	67,000	143,000	147,000
Outside Services	" .54xx	254,618	293,000	300,000	337,000	345,000
Total Information Tech		<u>732,457</u>	<u>941,000</u>	<u>786,000</u>	<u>1,003,000</u>	<u>1,046,000</u>
GENERAL & ADMINISTRATION						
Cost of Labor	6xxxxxx.51xx	3,091,137	2,813,000	2,810,000	2,987,000	3,195,000
Directors Fees	" .5101	51,512	80,000	74,000	62,000	64,000
District Insurance	" .5201	131,220	173,000	135,000	163,000	181,000
Travel	" .5202	20,551	8,000	9,000	8,000	8,000
Meetings & Seminars	" .5203	23,094	33,000	19,000	31,000	32,000
Dues & Subscriptions	" .5204	77,211	52,000	66,000	72,000	74,000
Directors Expenses	" .5205	58,531	50,000	46,000	50,000	51,000
Office Supplies	" .5301	81,861	50,000	42,000	50,000	51,000
Awareness/Conservation	" .5303	171,822	111,000	64,000	77,000	79,000
Postage	" .5304	2,607	3,000	5,000	3,000	3,000
Outside Services	" .5401	192,136	133,000	103,000	90,000	92,000
Legal	" .5402	152,749	143,000	107,000	130,000	140,000
Auditing	" .5403	12,528	20,000	16,000	20,000	23,000
Bank/Investment Svcs	" .5501	-	20,000	14,000	20,000	21,000
Regulatory Fees	" .5502	-	5,000	54,000	57,000	58,000
Election & Annexation	" .5503	-	5,000	-	2,000	2,000
Other/Reimbursements		29,119	10,000	16,000	10,000	10,000
Admin Credit Transfer.	4702	(640,668)	(936,000)	(667,000)	(1,020,000)	(1,105,000)
Total Gen. & Admin.		<u>3,455,410</u>	<u>2,773,000</u>	<u>2,913,000</u>	<u>2,812,000</u>	<u>2,979,000</u>
TOTAL EXPENSES		<u><u>\$32,644,857</u></u>	<u><u>\$36,856,000</u></u>	<u><u>\$ 36,984,000</u></u>	<u><u>\$ 39,936,000</u></u>	<u><u>\$ 42,853,000</u></u>

2017-18 OPERATING BUDGET
WASTEWATER



VALLECITOS WATER DISTRICT

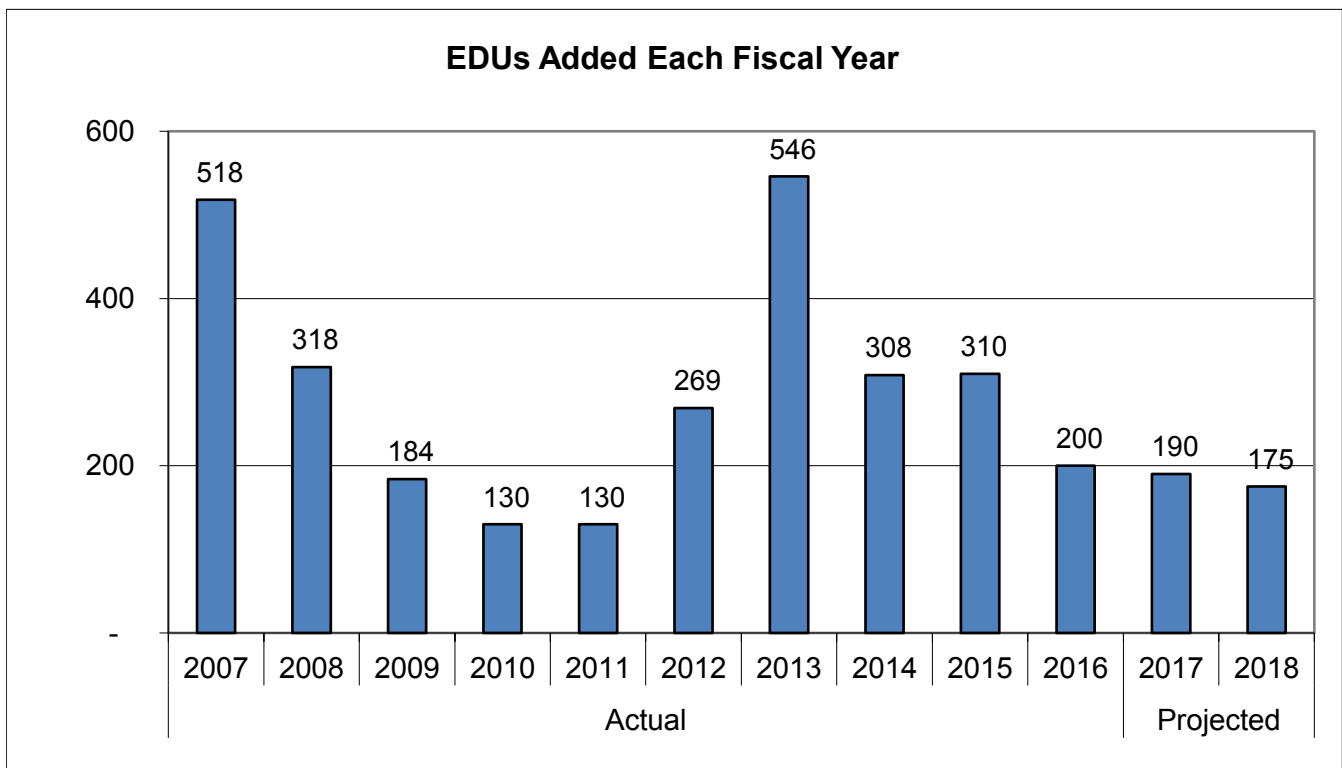
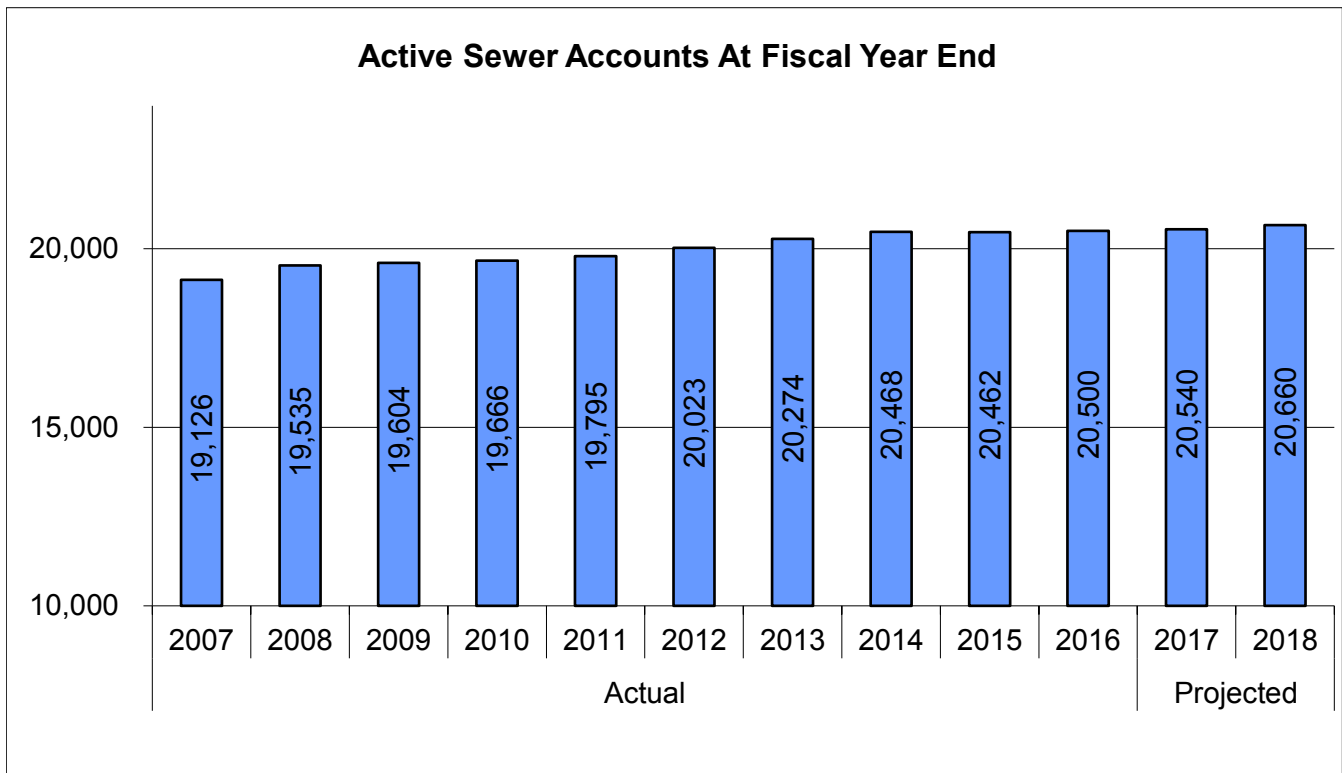

VALLECITOS WATER DISTRICT

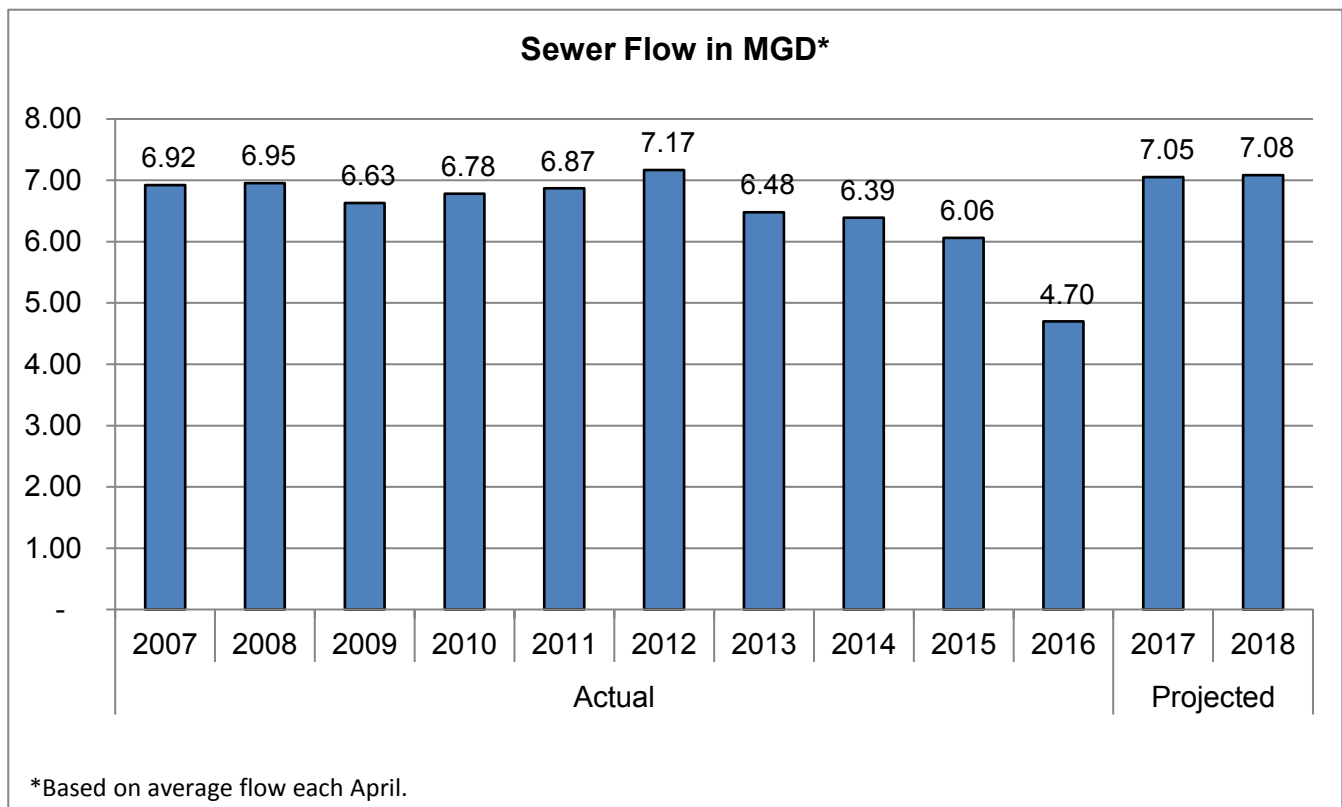
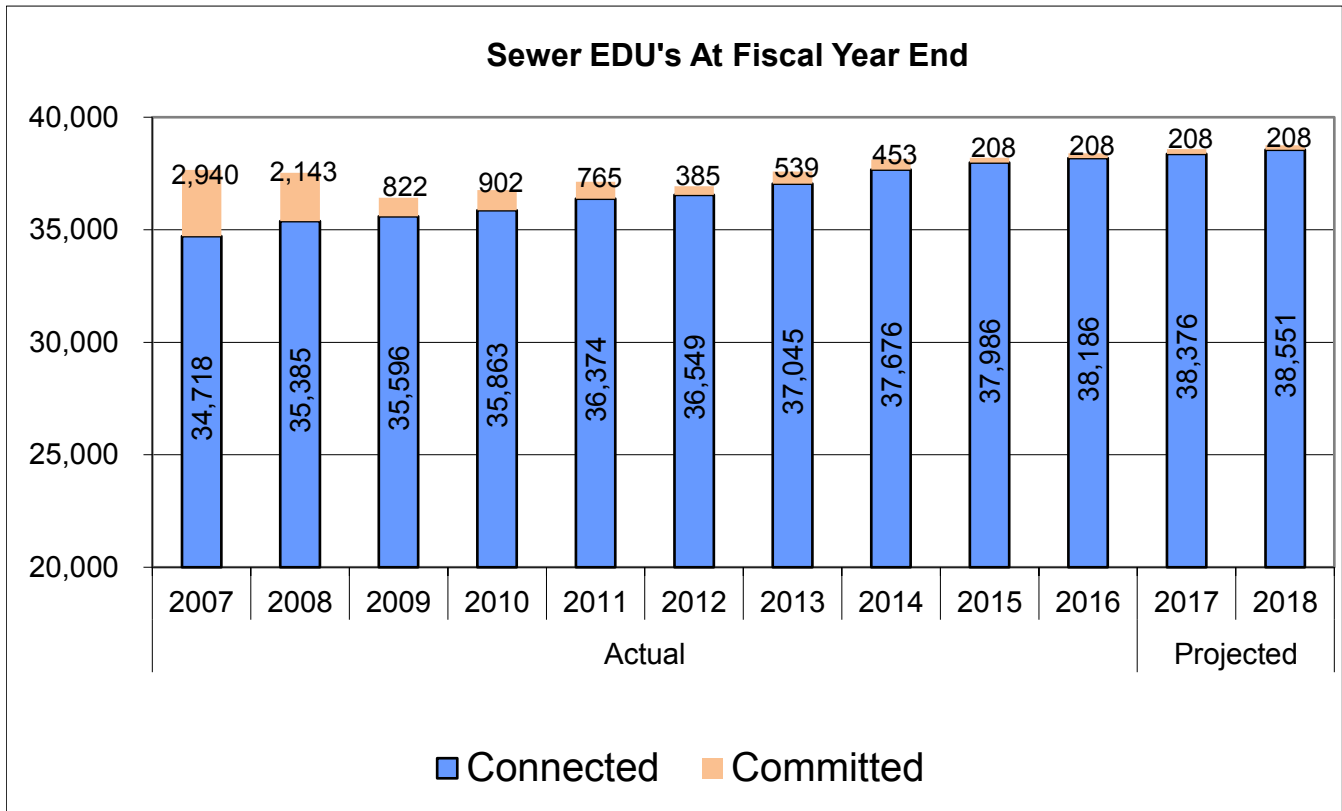

VALLECITOS WATER DISTRICT

BUDGET FOR THE YEAR ENDING JUNE 30, 2018

FUNCTION DEFINITIONS - WASTEWATER OPERATIONS

REVENUES

Sewer Service: Monthly charges to cover the cost to collect, treat and dispose of wastewater plus maintain the various wastewater facilities.

Reclaimed Water Sales: Revenue generated from contractual sale of reclaimed water to the Carlsbad Municipal Water District and the Olivenhain Municipal Water District on a cost recovery basis.

Other: Interest revenue, late charges, engineering fees and other miscellaneous revenues.

OPERATING EXPENSES

Collection and Conveyance: Maintaining flow in 249 miles of District sewer lines. Includes blockage removal, television inspection, and maintenance of pipeline system and manholes.

Lift Stations: Cost of lifting sewage flows at the Montiel Lift Station, Lake San Marcos Lift Station and Questhaven sewer lift station. Includes maintenance and power costs of the pumping systems.

Peroxide Station: Odor control by injection of hydrogen peroxide at outfall line on El Camino Real. Includes monitoring, maintenance, and chemicals. This site has been decommissioned, but continues to be maintained for potential future use.

Source Control: Costs to ensure compliance with federal, state, and local regulations as administered through the Encina Wastewater Authority.

Encina Disposal: Cost reimbursement to the Encina Wastewater Authority for processing wastewater and returning clean water to the environment.

Meadowlark Plant: All costs attributed to treating wastewater and for production and sale of reclaimed water to Carlsbad MWD, and OMWD including operation and maintenance of the plant, No. 1 Lift Station, and Mahr Reservoir.

Customer Accounts: Responds to customers, associated billing costs, and uncollectible accounts.

Equipment and Vehicles: Maintenance of sewer vehicles and equipment and transfer of a portion of administrative and water operations vehicle costs attributable to sewer.

Buildings and Grounds: A transfer of costs attributable to sewer.

Engineering: All attributable sewer engineering, capital facilities and inspection costs.

VALLECITOS WATER DISTRICT

BUDGET FOR THE YEAR ENDING JUNE 30, 2018

FUNCTION DEFINITIONS - WASTEWATER OPERATIONS (Continued)

Safety and Compliance: A transfer of safety and regulatory affairs costs attributable to sewer operations.

Information Technology: Centralization of the District's technology to maintain hardware, software, servers, networks, and interfaces.

General and Administrative

Cost of Labor:

- *Salaries* include all vacation, sick leave, and holiday time for sewer personnel.
- *Group Insurance* is health, vision, and dental costs for all sewer personnel.
- *Workers' Compensation Insurance* covers all sewer personnel.
- *Public Employees Retirement System (PERS)* participation costs for all sewer personnel.
- *Social Security* cost for all sewer personnel.
- *Other Taxes* include unemployment and other miscellaneous employee taxes for sewer personnel.

Travel costs for sewer personnel.

Meetings and Seminars fees for sewer personnel are to provide District representation and professional development.

Dues and Subscriptions are periodical costs for sewer-related activities.

Other includes miscellaneous expenses that do not specifically apply to any of the above-referenced categories.

Administrative Credit Transfer is the collection or recovery of overhead costs that apply to all construction work orders.

2017-18 WASTEWATER OPERATING EXPENSE BUDGET

\$13,217,000

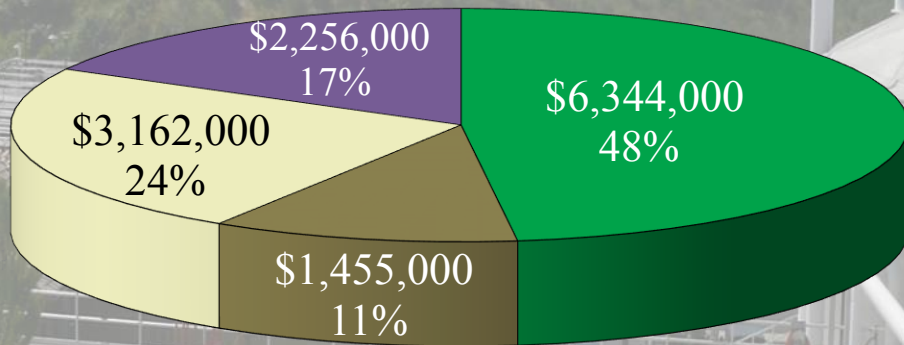

- Treatment
- General & Administrative
- Operation & Maintenance
- Collection & Conveyance

VALLECITOS WATER DISTRICT

WASTEWATER OPERATIONS BUDGET FOR THE YEAR ENDING JUNE 30, 2018

		<u>Actual</u> <u>FY 15-16</u>	<u>Budget</u> <u>FY 16-17</u>	<u>Projected</u> <u>FY 16-17</u>	<u>Budget</u> <u>FY 17-18</u>	<u>Estimated</u> <u>FY 18-19</u>
OPERATING REVENUES						
Sewer Service	4101	\$17,286,888	\$ 17,846,000	\$ 17,458,000	\$ 17,510,000	\$ 17,563,000
Reclaimed Water Sales	4102	1,069,074	1,938,000	1,676,000	2,055,000	2,080,000
Other	Various	98,210	77,000	78,000	78,000	79,000
Total Revenue		<u>18,454,172</u>	<u>19,861,000</u>	<u>19,212,000</u>	<u>19,643,000</u>	<u>19,722,000</u>
OPERATING EXPENSES						
Collection & Conveyance	3010000	1,762,895	2,262,000	1,893,000	2,256,000	2,377,000
Lift Stations	3020000	268,373	322,000	396,000	310,000	323,000
Peroxide Station	3050000	456	-	-	-	-
Source Control	3060000	132,532	193,000	143,000	178,000	188,000
Encina Disposal	3070000	2,485,765	2,691,000	2,539,000	2,870,000	2,956,000
Meadowlark Plant	3410000	2,750,187	3,484,000	2,957,000	3,474,000	3,482,000
Customer Accounts	4010000	370,109	461,000	382,000	458,000	485,000
Equipment & Vehicles	4210000	205,846	261,000	194,000	229,000	221,000
Buildings & Grounds	4110000	194,726	230,000	222,000	257,000	274,000
Engineering	5010000	618,839	656,000	556,000	710,000	669,000
Safety & Compliance	5210000	137,751	165,000	155,000	189,000	198,000
Information Technology	6230000	614,566	734,000	657,000	831,000	865,000
General & Admin.	6xxx000	1,270,897	1,261,000	1,285,000	1,455,000	1,556,000
Total Expense		<u>10,812,942</u>	<u>12,720,000</u>	<u>11,379,000</u>	<u>13,217,000</u>	<u>13,594,000</u>
OPERATING INCOME		<u>7,641,230</u>	<u>7,141,000</u>	<u>7,833,000</u>	<u>6,426,000</u>	<u>6,128,000</u>
LESS: TRANSFERS TO REPLACEMENT RESERVE						
		<u>7,641,230</u>	<u>7,141,000</u>	<u>7,833,000</u>	<u>6,426,000</u>	<u>6,128,000</u>
NET INCOME		<u>\$ -</u>	<u>\$ -</u>	<u>\$ -</u>	<u>\$ -</u>	<u>\$ -</u>

VALLECITOS WATER DISTRICT

WASTEWATER OPERATIONS BUDGET FOR THE YEAR ENDING JUNE 30, 2018

		<u>Actual</u> <u>FY 15-16</u>	<u>Budget</u> <u>FY 16-17</u>	<u>Projected</u> <u>FY 16-17</u>	<u>Budget</u> <u>FY 17-18</u>	<u>Estimated</u> <u>FY 18-19</u>
COLLECTION/CONVEYANCE						
Cost of Labor	3010xxx.51xx	\$ 1,179,829	\$ 1,607,000	\$ 1,363,000	\$ 1,517,000	\$ 1,619,000
Materials & Supplies	" .53xx	75,214	115,000	91,000	120,000	123,000
Chemicals	" .5350	306,209	300,000	237,000	300,000	308,000
Outside Services/Power	" .5xxx	201,643	240,000	202,000	319,000	327,000
Total Collection/Conveyance		<u>1,762,895</u>	<u>2,262,000</u>	<u>1,893,000</u>	<u>2,256,000</u>	<u>2,377,000</u>
LIFT STATIONS						
Cost of Labor	3020xxx.51xx	152,261	167,000	152,000	187,000	197,000
Materials & Supplies	" .53xx	29,291	40,000	122,000	45,000	46,000
Outside Services	" .54xx	43,965	75,000	75,000	28,000	29,000
Power	" .5306	42,856	40,000	47,000	50,000	51,000
Total Lift Stations		<u>268,373</u>	<u>322,000</u>	<u>396,000</u>	<u>310,000</u>	<u>323,000</u>
PEROXIDE STATION						
Cost of Labor	3050000.51xx	308	-	-	-	-
Outside Services/Power	" .5xxx	148	-	-	-	-
Total Peroxide Sta.		<u>456</u>	<u>-</u>	<u>-</u>	<u>-</u>	<u>-</u>
SOURCE CONTROL						
Cost of Labor	3060000.51xx	128,670	144,000	140,000	153,000	162,000
Materials & Supplies	" .53xx	3,862	42,000	2,000	21,000	22,000
Outside Services	" .54xx	-	7,000	1,000	4,000	4,000
Total Industrial Waste		<u>132,532</u>	<u>193,000</u>	<u>143,000</u>	<u>178,000</u>	<u>188,000</u>
ENCINA DISPOSAL	3070000.551	<u>2,485,765</u>	<u>2,691,000</u>	<u>2,539,000</u>	<u>2,870,000</u>	<u>2,956,000</u>
MEADOWLARK LIFT STATION						
Cost of Labor	3710000.51xx	64,322	122,000	73,000	102,000	107,000
Material & Supplies	" .53xx	45,498	40,000	8,000	60,000	62,000
Chemicals	" .5350	102,613	150,000	124,000	150,000	154,000
Outside Services	" .54xx	67,742	75,000	37,000	117,000	120,000
Power	" .5306	65,685	100,000	104,000	105,000	108,000
Total Lift Sta.		<u>345,860</u>	<u>487,000</u>	<u>346,000</u>	<u>534,000</u>	<u>551,000</u>

VALLECITOS WATER DISTRICT

WASTEWATER OPERATIONS BUDGET FOR THE YEAR ENDING JUNE 30, 2018

		<u>Actual</u>	<u>Budget</u>	<u>Projected</u>	<u>Budget</u>	<u>Estimated</u>
		<u>FY 15-16</u>	<u>FY 16-17</u>	<u>FY 16-17</u>	<u>FY 17-18</u>	<u>FY 18-19</u>
MEADOWLARK PLANT						
Cost of Labor	3410000.51xx	\$ 861,506	\$ 1,033,000	\$ 919,000	\$ 1,009,000	\$ 1,069,000
Materials & Supplies	" .53xx	258,411	442,000	360,000	375,000	322,000
Chemicals	" .5350	447,358	460,000	482,000	385,000	395,000
Outside Services	" .54xx	265,495	400,000	222,000	474,000	427,000
Power	" .5306	379,522	410,000	411,000	435,000	448,000
Telephone	" .5305	1,091	5,000	2,000	2,000	2,000
Total Meadowlark		<u>2,213,383</u>	<u>2,750,000</u>	<u>2,396,000</u>	<u>2,680,000</u>	<u>2,663,000</u>
MAHR RESERVOIR						
Cost of Labor	3810000.51xx	81,602	127,000	57,000	96,000	101,000
Materials & Supplies	" .53xx	23,861	10,000	20,000	10,000	10,000
Chemicals	" .5350	8,839	30,000	24,000	30,000	29,000
Outside Services	" .54xx	52,023	40,000	58,000	64,000	66,000
Power	" .5306	24,619	40,000	56,000	60,000	62,000
Total Mahr Reservoir		<u>190,944</u>	<u>247,000</u>	<u>215,000</u>	<u>260,000</u>	<u>268,000</u>
CUSTOMER ACCOUNTS						
Cost of Labor	4010000.51xx	273,567	362,000	290,000	364,000	389,000
Materials & Supplies	" .53xx	49,613	50,000	45,000	52,000	53,000
Outside Services	" .54xx	33,503	35,000	31,000	27,000	28,000
Uncollectible Accts.	" .5703	13,426	14,000	16,000	15,000	15,000
Total Cust. Accts.		<u>370,109</u>	<u>461,000</u>	<u>382,000</u>	<u>458,000</u>	<u>485,000</u>
EQUIPMENT & VEHICLES						
Cost of Labor	4210000.51xx	93,387	133,000	98,000	107,000	111,000
Materials & Supplies	" .53xx	40,089	41,000	27,000	50,000	51,000
Fuel	" .5307	39,122	52,000	32,000	47,000	48,000
Outside Services	" .54xx	33,248	35,000	37,000	25,000	11,000
Total Equip. & Veh.		<u>205,846</u>	<u>261,000</u>	<u>194,000</u>	<u>229,000</u>	<u>221,000</u>
BUILDING & GROUNDS						
Cost of Labor	4110000.51xx	51,009	123,000	60,000	98,000	110,000
Materials & Supplies	" .53xx	22,206	9,000	15,000	43,000	44,000
Outside Services	" .54xx	57,507	41,000	61,000	61,000	63,000
Power	" .5306	64,004	57,000	86,000	55,000	57,000
Total Building & Grounds		<u>194,726</u>	<u>230,000</u>	<u>222,000</u>	<u>257,000</u>	<u>274,000</u>
ENGINEERING						
Cost of Labor	5010000.51xx	543,886	626,000	551,000	612,000	639,000
Materials & Supplies	" .53xx	61,662	11,000	1,000	18,000	18,000
Outside Services	" .54xx	13,291	19,000	4,000	80,000	12,000
Total Engineering		<u>618,839</u>	<u>656,000</u>	<u>556,000</u>	<u>710,000</u>	<u>669,000</u>

VALLECITOS WATER DISTRICT

WASTEWATER OPERATIONS BUDGET FOR THE YEAR ENDING JUNE 30, 2018

		<u>Actual</u> <u>FY 15-16</u>	<u>Budget</u> <u>FY 16-17</u>	<u>Projected</u> <u>FY 16-17</u>	<u>Budget</u> <u>FY 17-18</u>	<u>Estimated</u> <u>FY 18-19</u>
SAFETY & REGULATORY AFFAIRS						
Cost of Labor	5210000.51xx	\$ 125,625	\$ 139,000	\$ 140,000	\$ 163,000	\$ 172,000
Materials & Supplies	" .53xx	2,315	13,000	7,000	13,000	13,000
Safety Support	" .54xx	<u>9,811</u>	<u>13,000</u>	<u>8,000</u>	<u>13,000</u>	<u>13,000</u>
Total Safety/Reg Affairs		<u>137,751</u>	<u>165,000</u>	<u>155,000</u>	<u>189,000</u>	<u>198,000</u>
INFORMATION TECH						
Cost of Labor	6230000.51xx	254,297	315,000	278,000	371,000	394,000
Materials & Supplies	" .53xx	91,665	101,000	72,000	137,000	140,000
Outside Services	" .54xx	<u>268,604</u>	<u>318,000</u>	<u>307,000</u>	<u>323,000</u>	<u>331,000</u>
Total Information Tech		<u>614,566</u>	<u>734,000</u>	<u>657,000</u>	<u>831,000</u>	<u>865,000</u>
GENERAL & ADMINISTRATION						
Cost of Labor	6xxxxxx.51xx	1,355,856	1,363,000	1,265,000	1,498,000	1,612,000
Directors Fees	" .5101	37,813	62,000	53,000	58,000	59,000
District Insurance	" .5201	126,074	172,000	129,000	157,000	176,000
Travel	" .5202	-	1,000	-	1,000	1,000
Meetings & Seminars	" .5203	1,224	11,000	2,000	10,000	10,000
Dues & Subscriptions	" .5204	421	17,000	24,000	39,000	40,000
Office Supplies	" .5301	18,547	10,000	10,000	11,000	11,000
Postage	" .5304	-	2,000	12,000	6,000	6,000
Outside Services	" .5401	59,492	54,000	18,000	40,000	41,000
Legal	" .5402	140,797	142,000	107,000	142,000	153,000
Auditing	" .5403	12,062	17,000	16,000	17,000	20,000
Bank/Investment Svcs	" .5501	-	18,000	14,000	16,000	16,000
Regulatory Fees	" .5502	-	-	-	3,000	3,000
Other	" .5702	3,123	5,000	5,000	5,000	5,000
Admin Credit Trans	4702	<u>(484,512)</u>	<u>(613,000)</u>	<u>(370,000)</u>	<u>(548,000)</u>	<u>(597,000)</u>
Total Gen. & Admin.		<u>1,270,897</u>	<u>1,261,000</u>	<u>1,285,000</u>	<u>1,455,000</u>	<u>1,556,000</u>
TOTAL EXPENSES		<u><u>\$10,812,942</u></u>	<u><u>\$ 12,720,000</u></u>	<u><u>\$ 11,379,000</u></u>	<u><u>\$ 13,217,000</u></u>	<u><u>\$ 13,594,000</u></u>

VALLECITOS WATER DISTRICT

BUDGET FOR THE YEAR ENDING JUNE 30, 2018

SALARY AND BENEFIT RECAP

	<u>Actual FY 15-16</u>	<u>Budget FY 16-17</u>	<u>Projected FY 16-17</u>	<u>Budget FY 17-18</u>	<u>Estimated FY 18-19</u>
SALARIES					
Water Operations	\$ 5,136,345	\$ 5,125,000	\$ 4,968,000	\$ 5,117,000	\$ 5,415,000
Wastewater Operations	3,245,093	3,801,000	3,269,000	3,783,000	4,032,000
Subtotal	8,381,438	8,926,000	8,237,000	8,900,000	9,447,000
Labor Posted to Work Orders*	664,063	762,000	594,000	772,000	816,000
TOTAL SALARIES	<u>9,045,501</u>	<u>9,688,000</u>	<u>8,831,000</u>	<u>9,672,000</u>	<u>10,263,000</u>
BENEFITS					
Public Employee Retirement	1,439,025	1,990,000	1,862,000	2,097,000	2,199,000
Group Insurance	2,051,940	2,655,000	2,333,000	2,677,000	2,848,000
Social Security	667,480	741,000	664,000	740,000	785,000
Workers' Comp Insurance	212,845	239,000	193,000	218,000	238,000
457 Contribution Match	-	112,000	203,000	108,000	108,000
Other Taxes and Benefits	40,009	38,000	25,000	28,000	30,000
TOTAL BENEFITS	<u>4,411,299</u>	<u>5,775,000</u>	<u>5,280,000</u>	<u>5,868,000</u>	<u>6,208,000</u>
TOTAL SALARIES & BENEFITS	<u>\$ 13,456,800</u>	<u>\$ 15,463,000</u>	<u>\$ 14,111,000</u>	<u>\$ 15,540,000</u>	<u>\$ 16,471,000</u>
 Benefits as a Percentage of Salaries	 <u>48.8%</u>	 <u>59.6%</u>	 <u>59.8%</u>	 <u>60.7%</u>	 <u>60.5%</u>
 Operations	 52.00	 53.00	 52.00	 52.00	 52.00
Engineering	16.00	16.00	16.00	16.00	16.00
Finance	24.25	24.75	22.75	23.00	23.00
Administration	<u>17.25</u>	<u>18.00</u>	<u>16.75</u>	<u>16.75</u>	<u>16.75</u>
Total Funded FTEs	<u>109.50</u>	<u>111.75</u>	<u>107.50</u>	<u>107.75</u>	<u>107.75</u>
 Total Budgeted FTEs	 115.25				

* There is also a labor overhead charge to work orders to cover benefit costs which are a part of the credit in the General and Administration sections of Water and Wastewater operations.

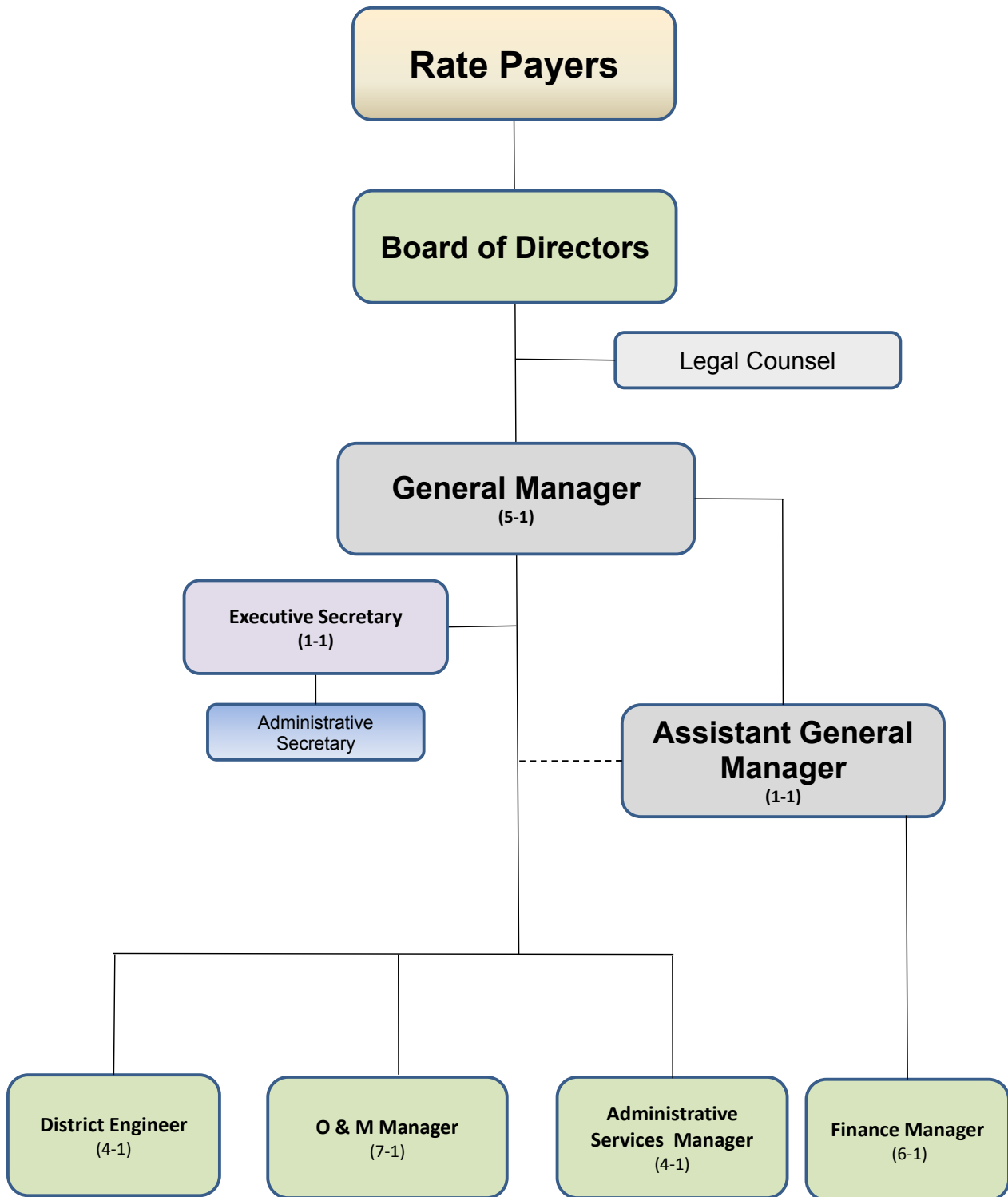

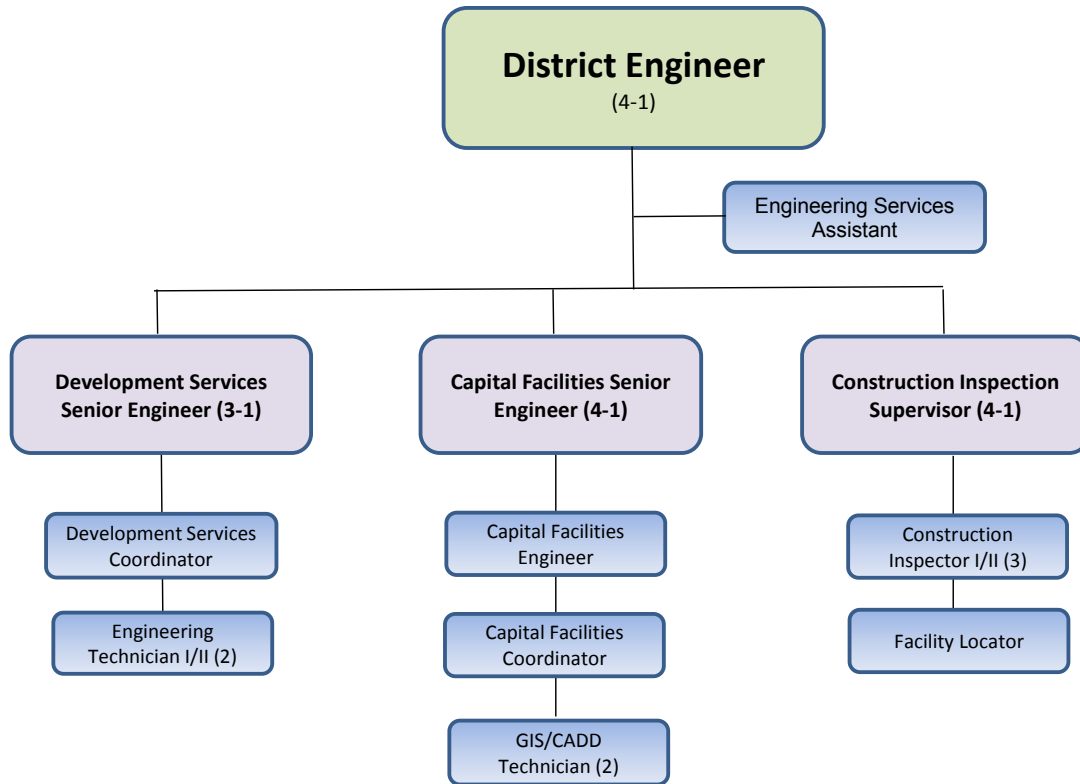

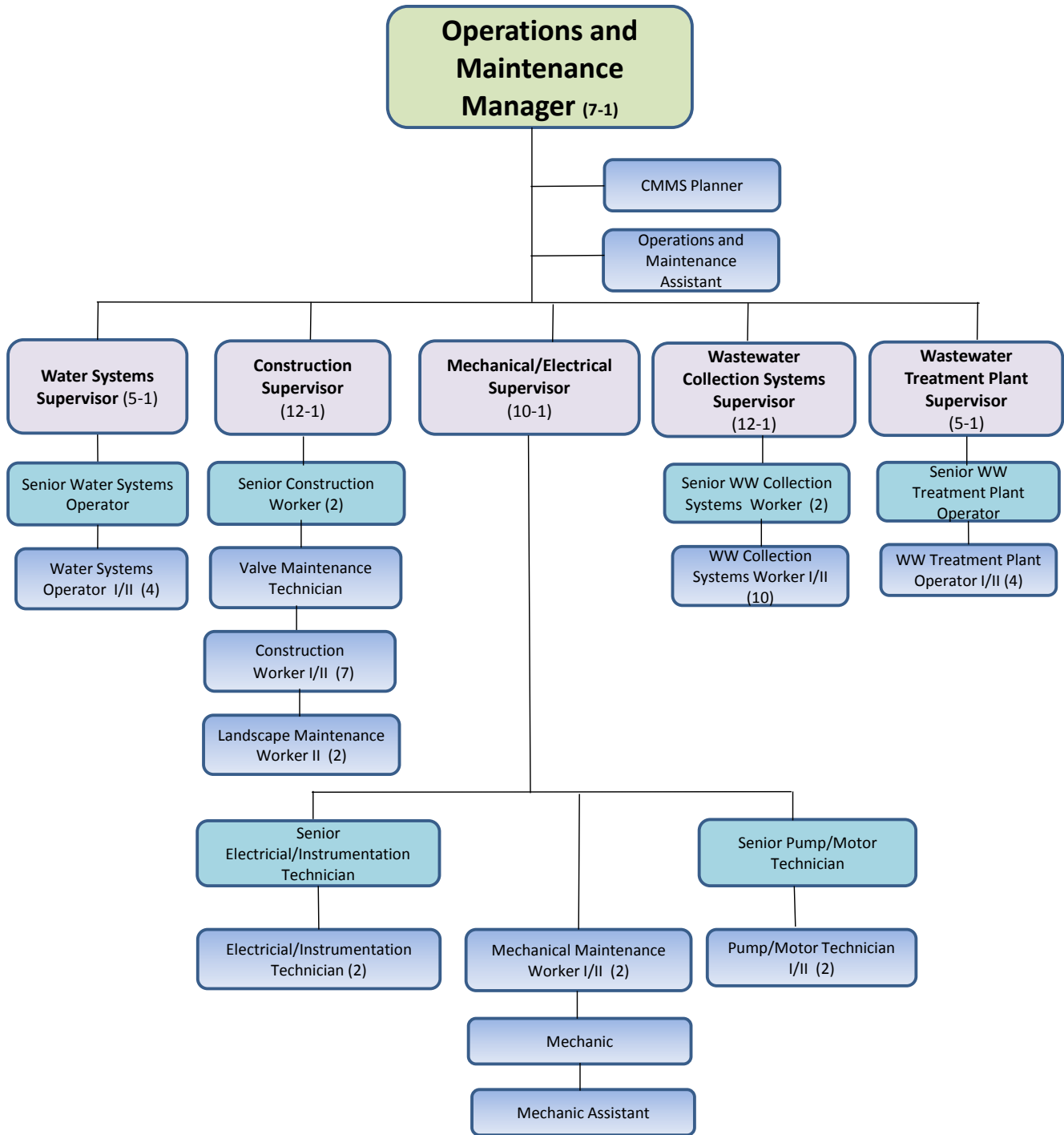

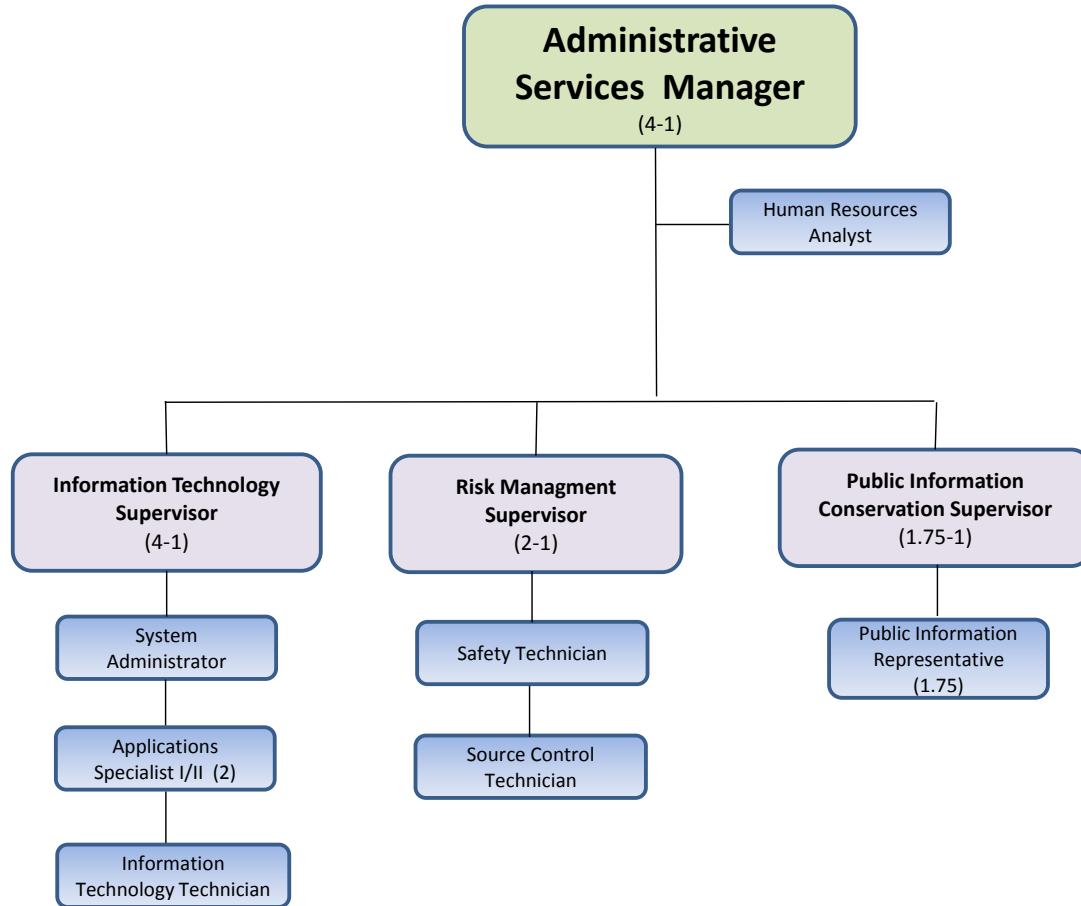

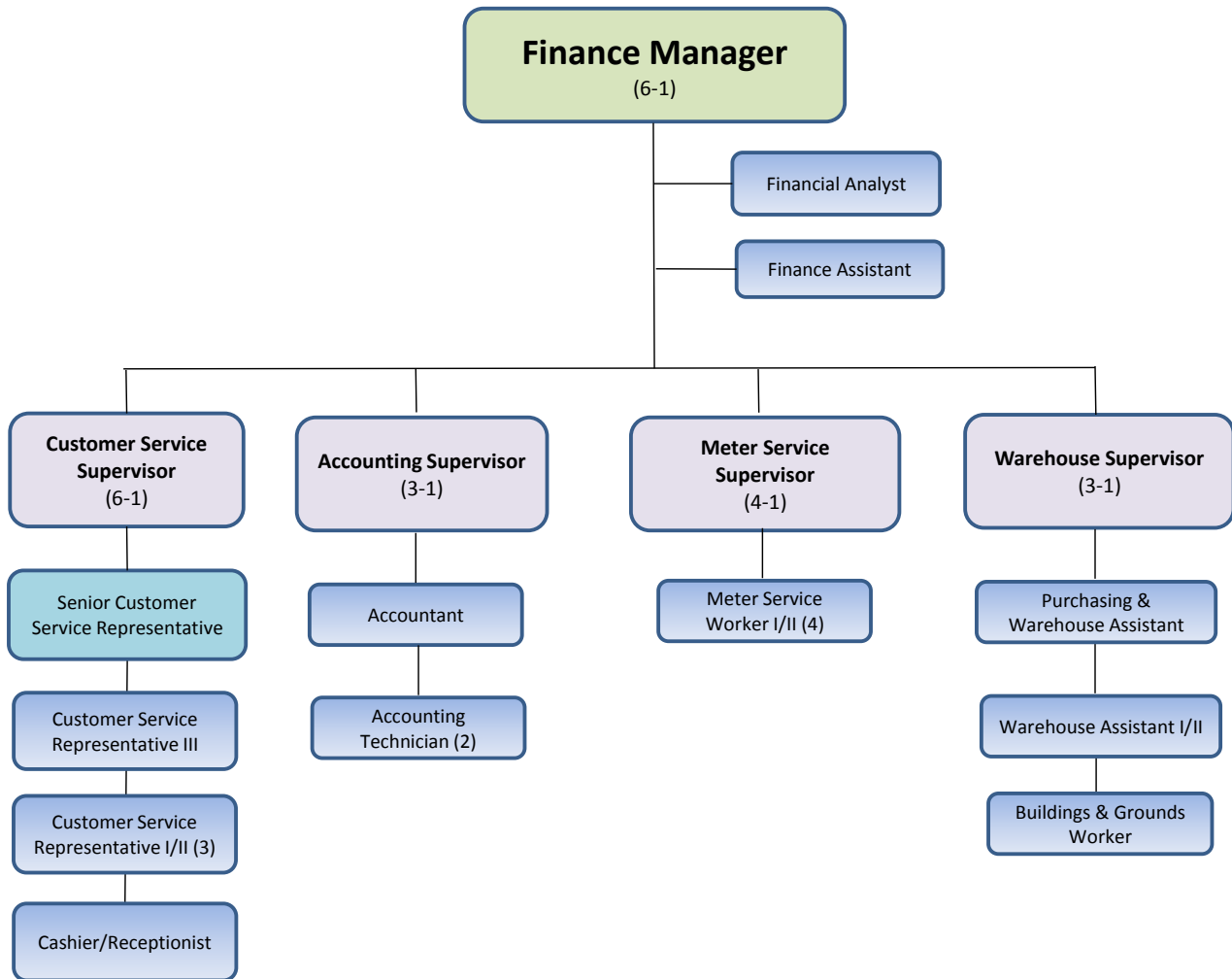

VALLECITOS WATER DISTRICT

2017-18 PERSONNEL BUDGET

POSITIONS/PERSONNEL:

Management will scrutinize the need for all positions and only fill positions if absolutely necessary. The fiscal year 2017-18 budget includes: two reclassifications and four eliminated positions as outlined below.

RECLASSIFICATIONS:

Applications Specialist II - Estimated Additional Annual Cost: \$2,244

This position's job description was updated to better reflect the duties and responsibilities performed. As a result the salary for this position will increase by 2.5% annually.

Cashier/Receptionist - Estimated Additional Annual Cost: \$11,500

As a result of eliminating one full-time cashier/receptionist, the part-time position is increased to full-time for coverage at the customer service counter.

ELIMINATED POSITIONS:

Meter Service Worker III - Estimated Annual Savings: \$80,500 plus benefits

This position was vacated when the incumbent left the District. The fluctuating workload of the will be absorbed by other staff and outside contractors.

Public Informaiton Representative - Estimated Annual Savings: \$77,200 plus benefits

This position was vacated when the incumbent left the District. The workload will be redistributed within the existing public information department.

Wastewater Collections Systems Worker I/II - Estimated Annual Savings: \$68,000 plus benefits

This position was vacated when the incumbent left the District. The Operations Manager determined the work could be redistributed within the department over the short-term.

Cashier/Receptionist - Estimated Annual Savings: \$64,700 plus benefits

This position was vacated when the incumbent was promoted within the department. The reclassification of the part-time cashier/receptionist to full-time will provide coverage at the customer service counter.

VALLECITOS WATER DISTRICT

2017-18 PUBLIC AWARENESS AND CONSERVATION PROGRAM BUDGET

<u>REBATE PROGRAMS *</u>	Prj 2018100042	W/O 117447	
To encourage the purchase of qualified low flow devices, appliances, artificial turf or rebates to customers who remove their existing turf grass and install a low-water landscape (i.e., Cash for Grass program.)			\$ 1,000
<u>OUTREACH & ADVERTISING</u>	Prj 2018100043	W/O 117448	
For purchase of items and services used to assist customers in becoming better informed about water related issues. Includes but not limited to: purchase of videos, books, displays and promotional items; advertising; cost to participate in community events; employee education; and to provide tours of District facilities. Includes cost to produce and mail newsletters, consumer confidence report, brochures, bill inserts, special hearing notifications, and others as needed.			52,000
<u>VIDEO PRODUCTION</u>	Prj 2018100044	W/O 123555	
Cost to hire outside production company to produce videos highlighting the District or for internal staff to purchase supplies and services to create videos. Videos to be shown during tours of the District, speaking engagements, on the VWD website and/or on social media.			4,200
<u>EDUCATION</u>	Prj 2018100045	W/O 117451	
For continued development and purchase of materials designed to promote and implement K-12 education programs. This includes the Splash Science Mobile Lab visits to area elementary schools and payment for bus transportation to Jack's Pond Park and Heritage Park to listen to educational water history information by District staff. Also includes bus transportation for school tours of the District. Includes materials and costs to participate in annual Water Awareness Campaign (4th grade calendar/poster contest), such as the purchase of calendars, entry forms, prizes for entrants and poster contest winners. Also includes participation in Palomar College GEAR UP program.			7,600
<u>COOPERATIVE PROGRAMS*</u>	Prj 2018100046	W/O 117452	
For participation in cost-sharing programs such as residential surveys; large property audits, which are outsourced due to extensive staff time that would be required; customer service surveys; and supplies such as dye tablets, showerheads and moisture probes.			4,000
<u>WATERWISE LANDSCAPE</u>	Prj 2018100047	W/O 117453	
To promote low water use landscape and irrigation practices. Includes the cost for sponsoring, maintaining and upgrading water-wise demonstration gardens**, landscape irrigation/plant selection workshops, signage and promotion of demonstration gardens, waterwise plant promotions, and purchase of waterwise landscape brochures and publication reprints. ** Demonstration gardens include: Sustainable Demonstration Garden at VWD Administration building, Heritage Park native plant garden and Jack's Pond Park native plant garden.			4,500
<u>MEMBERSHIPS & EQUIPMENT</u>	Prj 2018100048	W/O 117454	
To maintain memberships in related organizations and committees and for the purchases of new or replacement equipment.			2,500
<u>COMMERCIAL/INDUSTRIAL</u>	Prj 2018100049	W/O 117455	
To assist large commercial and public agency customers by providing workshops, written materials, monetary incentives, and using outside consultants.			1,200
TOTAL PUBLIC AWARENESS/CONSERVATION PROGRAM BUDGET			\$ 77,000

* Uncertainty in the funding from the Metropolitan Water District may adversely impact the availability of programs.

2017-18 CAPITAL BUDGET



VALLECITOS WATER DISTRICT

Comprehensive Project List

OLUM

Page Number	Project Number	Project Title	Funding Source	Previous Budget & Amendments	Estimated Amt Expended @ 6/30/17	Fiscal Year 2017-18	
						Carryforward	New Request
Carryover Projects							
			Check				
36	90001	Encina Parallel Land Outfall	- 220	\$ 28,150,000	\$ 140,000	\$ 28,010,000	\$ 2,850,000
37	71004	San Marcos Interceptor	- 210 & 220	19,700,000	13,600,000	6,100,000	-
38	2013100001	Coronado Hills Tank #2	- 120	6,000,000	-	6,000,000	-
39	2016100002	Chlorine Contact Tank Expansion	- 220	1,950,000	160,000	1,790,000	2,865,000
40	2016100003	Montiel Gravity Outfall	- 210 & 220	1,750,000	145,000	1,605,000	2,975,000
41	71084	Meadowlark Tank No. 3	- 110 & 120	4,552,000	500,000	4,052,000	-
42	71219	Mountain Belle Pump Station	- 120	3,860,000	100,000	3,760,000	-
43	90003	Rock Springs Sewer Replacement	- 210 & 220	2,460,000	525,000	1,935,000	705,000
44	2017100001	Encina Wastewater Authority FY 16/17	- 210	2,869,000	1,384,000	1,485,000	(835,000)
45	2017100002	MRF: On-site Generation of Sodium Hypochlorite	- 210	2,000,000	-	2,000,000	-
46	2012100002	Richland Invert Replacement	- 210	1,135,000	13,000	1,122,000	350,000
47	71177	Land Outfall Clearing & Access Road	- 210	945,000	350,000	595,000	205,000
48	2014100003	Water and Sewer Master Plan	- 120 & 220	1,050,000	950,000	100,000	-
49	80001	Old Questhaven Sewer Replacement	- 210 & 220	835,000	1,000	834,000	-
50	2016100005	Expansion of the Men's Locker Room in Building B	- 110 & 210	575,000	140,000	435,000	235,000
51	2015100002	Audiovisual Upgrade	- 110 & 210	500,000	500,000	-	250,000
52	90007	City of San Marcos Joint Projects	- 110 & 210	670,000	90,000	580,000	80,000
53	2013100006	High Point Pipeline	- 120	700,000	-	700,000	-
54	2016100004	District-wide Valve Replacement Program	- 110	700,000	350,000	350,000	-
55	2014100002	N W Lake San Marcos Sewer Replacement & Relining Project	- 210	605,000	2,000	603,000	-
56	2014100004	Asset Management Replacement Schedule	- 110 & 210	600,000	-	600,000	-
57	71126	Vulnerability Assessment Improvements	- 110 & 210	447,700	336,700	111,000	-
58	2014100008	North Vista Pressure Reducing Station Upgrade	- 110	242,000	60,000	182,000	123,000
59	2017100004	Lift Station 1 Wet Well Room Repairs	- 210	295,000	80,000	215,000	-
60	2016100007	Rock Springs Valve Replacement	- 110	250,000	-	250,000	15,000
61	2014100007	South Vista Pressure Reducing Station Upgrade	- 110	234,000	60,000	174,000	21,000
62	2017100005	Fire Services - Backflow Preventer Upgrades	- 110	250,000	50,000	200,000	-
63	2016100014	Via Vera Cruz Tank Hill Stabilization	- 110	135,000	8,000	127,000	10,000
64	2016100011	Fulton Road and NCTD Sewer Line Rehabilitation	- 210	143,000	30,000	113,000	-
65	2016100008	Palos Vista Pump Station - Motor Replacement	- 110	118,000	54,000	64,000	-
66	2017100009	Building B Laminate Floor Replacement	- 110 & 210	40,000	-	40,000	-
67	2017100011	Lake San Marcos Lift Station - Motor Replacement	- 210	36,000	18,000	18,000	-
68	2017100016	HVAC Pump and Motor Replacement	- 110 & 210	20,000	-	20,000	-
				\$ 83,816,700	\$ 19,646,700	\$ 64,170,000	\$ 9,849,000
New Projects							
69	2018100001	Encina Wastewater Authority Five Year Plan	- 210 & 220	-	-	-	19,245,000
70	2018100002	Elsler Lane Water Line Improvements	- 110	-	-	-	1,765,000
71	2018100003	Schoolhouse Tank Refurbishment	- 110	-	-	-	675,000
72	2018100004	Las Posas 10-inch Water Main Replacement	- 110	-	-	-	580,000
73	2018100005	Stargaze Court Water Line Replacement	- 110	-	-	-	400,000
74	2018100006	Palos Vista Pump Station - Generator	- 110	-	-	-	325,000
75	2018100007	Solar Panel Invertor Replacement	- 110 & 210	-	-	-	295,000
76	2018100008	Laurels Sewer Lining	- 210	-	-	-	210,000
77	2018100009	MRF - Replace the Influent Pumps & Motors	- 210	-	-	-	195,000
78	2018100010	Nursery Valve Relocation	- 210	-	-	-	190,000
79	2018100011	MRF - Tertiary Influent Chamber Repairs	- 250	-	-	-	115,000
80	2018100012	Sewer Replacement and I&I Repairs	- 210	-	-	-	100,000
81	2018100013	South Lake - Facility Upgrades	- 110	-	-	-	95,000
82	2018100014	Replace Roofs on Equipment Storages	- 110 & 210	-	-	-	77,000
83	2018100015	Coronado Hills Chlorine Injection System	- 110	-	-	-	65,000
84	2018100016	Building A Kitchens	- 110	-	-	-	65,000
85	2018100017	Refurbish Pumps at North Twin Oaks Pump Station	- 110	-	-	-	63,000
86	2018100018	Wulff Pump Station Pumps & Motors	- 110	-	-	-	60,000
87	2018100019	South Lake Pump Station Valves	- 110	-	-	-	45,000
88	2018100020	Solar Panels at Poinsettia Odor Control Injection	- 220	-	-	-	35,000
89	2018100021	Admin Emergency Generator - Auto Transfer Switch	- 110 & 210	-	-	-	30,000
90	2018100022	Gates for Twin Oaks Reservoir Access Road	- 120	-	-	-	25,000
91	2018100023	Palomar Tank - Valve Replacement	- 110	-	-	-	25,000
92	2018100024	Mountain Belle Tank - Valve Replacement	- 110	-	-	-	20,000
93	2018100025	Office Wall for Senior Construction Workers	- 110 & 210	-	-	-	17,000
94	2018100026	Office Wall for Applications Specialist Staff	- 110 & 210	-	-	-	17,000
95	TBA	Future Projects					22,853,000
				\$ -	\$ -	\$ -	\$ 47,587,000
				\$ 83,816,700	\$ 19,646,700	\$ 64,170,000	\$ 57,436,000
						\$121,606,000	

VALLECITOS WATER DISTRICT

Comprehensive Project List

283.9841734

Project Total	Spending by Fiscal Year						Page Number
	2017-18	2018-19	2019-20	2020-21	2021-22	2022 to 2027	
\$ 31,000,000	\$ 80,000	\$ 150,000	\$ 500,000	\$ 500,000	\$ 3,800,000	\$ 25,830,000	36
19,700,000	1,600,000	4,500,000	-	-	-	-	37
6,000,000	-	-	-	-	-	6,000,000	38
4,815,000	1,000	1,000	1,000	1,000	1,000	4,650,000	39
4,725,000	380,000	2,560,000	1,640,000	-	-	-	40
4,552,000	-	3,052,000	1,000,000	-	-	-	41
3,860,000	-	-	-	-	-	3,760,000	42
3,165,000	2,640,000	-	-	-	-	-	43
2,034,000	650,000	-	-	-	-	-	44
2,000,000	-	300,000	1,700,000	-	-	-	45
1,485,000	12,000	300,000	1,160,000	-	-	-	46
1,150,000	800,000	-	-	-	-	-	47
1,050,000	100,000	-	-	-	-	-	48
835,000	-	-	-	-	-	834,000	49
810,000	670,000	-	-	-	-	-	50
750,000	250,000	-	-	-	-	-	51
750,000	650,000	-	10,000	-	-	-	50
700,000	-	700,000	-	-	-	-	53
700,000	175,000	175,000	-	-	-	-	54
605,000	78,000	525,000	-	-	-	-	55
600,000	200,000	200,000	200,000	-	-	-	56
447,700	111,000	-	-	-	-	-	57
365,000	305,000	-	-	-	-	-	58
295,000	215,000	-	-	-	-	-	59
265,000	15,000	220,000	30,000	-	-	-	60
255,000	195,000	-	-	-	-	-	61
250,000	50,000	50,000	50,000	50,000	-	-	62
145,000	137,000	-	-	-	-	-	63
143,000	113,000	-	-	-	-	-	64
118,000	32,000	32,000	-	-	-	-	65
40,000	40,000	-	-	-	-	-	66
36,000	18,000	-	-	-	-	-	67
20,000	20,000	-	-	-	-	-	68
\$ 93,665,700	\$ 9,537,000	\$ 12,765,000	\$ 6,291,000	\$ 551,000	\$ 3,801,000	\$ 41,074,000	
19,245,000	3,236,000	4,703,000	4,796,000	3,400,000	3,110,000	-	69
1,765,000	15,000	65,000	410,000	1,275,000	-	-	70
675,000	675,000	-	-	-	-	-	71
580,000	15,000	565,000	-	-	-	-	72
400,000	400,000	-	-	-	-	-	73
325,000	325,000	-	-	-	-	-	74
295,000	295,000	-	-	-	-	-	75
210,000	210,000	-	-	-	-	-	76
195,000	65,000	65,000	65,000	-	-	-	77
190,000	190,000	-	-	-	-	-	78
115,000	115,000	-	-	-	-	-	79
100,000	100,000	-	-	-	-	-	80
95,000	95,000	-	-	-	-	-	81
77,000	77,000	-	-	-	-	-	82
65,000	65,000	-	-	-	-	-	83
65,000	65,000	-	-	-	-	-	84
63,000	63,000	-	-	-	-	-	85
60,000	60,000	-	-	-	-	-	86
45,000	45,000	-	-	-	-	-	87
35,000	35,000	-	-	-	-	-	88
30,000	30,000	-	-	-	-	-	89
25,000	25,000	-	-	-	-	-	90
25,000	25,000	-	-	-	-	-	91
20,000	20,000	-	-	-	-	-	92
17,000	17,000	-	-	-	-	-	93
17,000	17,000	-	-	-	-	-	94
22,853,000	-	1,810,000	1,190,000	1,363,000	875,000	17,615,000	95
\$ 47,587,000	\$ 6,280,000	\$ 7,208,000	\$ 6,461,000	\$ 6,038,000	\$ 3,985,000	\$ 17,615,000	
\$ 141,252,700	\$ 15,817,000	\$ 19,973,000	\$ 12,752,000	\$ 6,589,000	\$ 7,786,000	\$ 58,689,000	

Capital Improvement Program Encina Parallel Land Outfall

Description: This project calls for the installation of approximately 43,500 feet of new outfall pipeline varying between 18 and 30 inches in diameter. The pipeline will parallel the existing sewer interceptor from Lift Station No. 1 to the Encina Water Pollution Control Facility

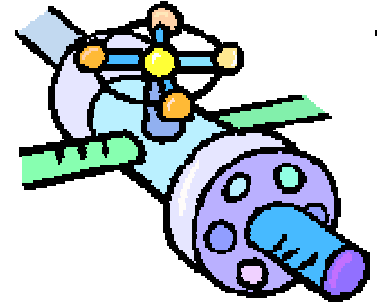

Project Manager: James Gumpel

Department: Engineering

Project: 90001

Funding Source: 100% Fund 220 – Sewer Capacity

Comments: This project will increase the District’s sewer handling capacity by allowing more wastewater flow to the Encina Water Pollution Control Facility. The District will work with other interested agencies (City of Carlsbad, Buena Sanitation District & City of Vista) when possible in pursuit of cost-sharing alternatives.

Operations Impact: Increased sewerage handling capacity and additional flexibility & redundancy in outfall system during average and low flow periods. Annual, routine sewer pipeline maintenance is expected with the completion of this project.

Project Spending Plan

Project Phase	Previous Spending	FY 17/18	FY 18/19	FY 19/20	FY 20/21	FY 21/22 & Thereafter	Total
Planning	\$140,000	\$80,000	\$100,000				\$320,000
Design			\$50,000	\$500,000	\$500,000	\$1,900,000	\$2,950,000
Construction						\$27,730,000	\$27,730,000
Total	\$140,000	\$80,000	\$150,000	\$500,000	\$500,000	\$29,630,000	\$31,000,000

FY 2017/18 Budget Request - \$2,850,000

Estimated Project Timeline

Project Approval	Planning		Design		Construction		Completion
	Begin	End	Begin	End	Begin	End	
Jul 2008	Jan 2009	Dec 2018	Jan 2019	Jun 2021	Jul 2021	Jun 2025	Jun 2025

Capital Improvement Program San Marcos Interceptor

Description: The project consists of three separate phases constructing approximately 9,000 LF of 36" sewer interceptor replacing an existing 21" sewer line. The existing line is prone to groundwater inflow and infiltration (I&I) and at risk for failure. The sewer interceptor runs along San Marcos Creek from north of the 78 FWY past McMahr Road. The project includes open cut and tunnel section as well as right of way acquisition.



Project Manager: James Gumpel

Department: Engineering

Project: 71004

Funding Source: 31% Fund 210 – Sewer Replacement
69% Fund 220 – Sewer Capacity

Comments: This project is identified in the 2002 Master Plan. The reduction of I&I will help extend the life of the sewer system downstream of the San Marcos interceptor and reduce unnecessary treatment of groundwater at Encina and Meadowlark. The new line will also reduce the likelihood of spills within San Marcos Creek. Design and land acquisition will move forward in FY 13/14 for the last phase between Via Vera Cruz and Pacific Street in order to be consistent with the future road within the Creek District. The City of San Marcos will reimburse VWD for \$77,000 in design costs for the last phase of this project. The last phase will also include a construction cost reimbursement from the City which is estimated at \$400,000. The construction cost reimbursement will be finalized after actual bid prices are received for the project.

Operations Impact: Minimal impact is anticipated as this project increases the size of an existing sewer line and does not add significant lineal footage of sewer for maintenance.

Project Spending Plan

Project Phase	Previous Spending	FY 17/18	FY 18/19	FY 19/20	FY 20/21	FY 21/22 & Thereafter	Total
Planning	\$800,000	\$130,000					\$930,000
Design	\$2,600,000	\$270,000					\$2,870,000
Construction	\$10,200,000	\$1,200,000	\$4,500,000				\$15,900,000
Total	\$13,600,000	\$1,600,000	\$4,500,000	\$0	\$0	\$0	\$19,700,000

FY 2017/18 Budget Request - \$0

Estimated Project Timeline

Project Approval	Planning		Design		Construction		Completion
	Begin	End	Begin	End	Begin	End	
Jul 1996	Jul 1996	Jun 2007	Jul 1998	Apr 2018	May 2018	Jan 2019	Jan 2019

Capital Improvement Program Coronado Hills Tank #2

Description: Build-out demands for the 1530, 1115 and 1320 pressure zones are projected to require a storage volume of 9.63 million gallons over and above existing storage capacity. This project will add 4.73 million gallons of potable water storage to meet the projected near-term total storage deficits in the 1530 and neighboring pressure zones. This reservoir will be constructed on the same site as the existing Coronado Hills Tank.



Project Manager: Jason Hubbard

Department: Engineering

Project: 2013100001

Funding Source: 100% Fund 120 – Water Capacity

Comments: The existing Coronado Hills Tank resides on a large, flat parcel that can accommodate additional storage reservoirs with little grading and preparation efforts. The ultimate plan is to locate a total of 3 tanks at this site, with a Coronado Hills #3 tank sized for 3.21 million gallons being constructed around 2030. The Master Plan has identified this as Project R-3.

Operations Impact: The project will add 4.73 million gallons of potable water storage to the service system.

Project Spending Plan

Project Phase	Previous Spending	FY 17/18	FY 18/19	FY 19/20	FY 20/21	FY 21/22 & Thereafter	Total
Planning						\$50,000	\$50,000
Design						\$690,000	\$690,000
Construction						\$5,260,000	\$5,260,000
Total	\$0	\$0	\$0	\$0	\$0	\$6,000,000	\$6,000,000

FY 2017/18 Budget Request - \$0

Estimated Project Timeline

Project Approval	Planning		Design		Construction		Completion
	Begin	End	Begin	End	Begin	End	
Jul 2012	Oct 2022	Dec 2022	Jan 2023	Aug 2023	Sep 2023	Mar 2024	Mar 2024

Capital Improvement Program Chlorine Contact Tank Expansion

Description: Expand the existing Chlorine Contact Tank (CCT) at the Meadowlark Reclamation Facility (MRF) from 5 million gallons a day (MGD) to 6.5 MGD. Evaluate updating CCT process to utilize Ultraviolet Sterilization.



Project Manager: James Gumpel

Department: Engineering

Project: 2016100002

Funding Source: 100% Fund 220 – Sewer Capacity

Work Order: 167177

Comments: The existing CCT were part of the original expansion of MRF in the 80’s. During the latest expansion of MRF which started in 2005, the CCTs were rerated to handle the expanded flow but were not updated. Currently the CCTs remain one of the bottlenecks in the process at MRF.

Chlorine contact tanks (CCTs) at Meadowlark Water Reclamation Facility (MRF) can process up to 5 million gallons per day (MGD) of reclaimed water; all of the other treatment components at MRF has the ability to process up to 6.5 MGD. This was identified in the draft Nutrient Removal Study, which indicated that MRF has the ability to increase the daily treatment capacity to 6.5 MGD. The District as a member of the North San Diego County Water Reuse Coalition secured a grant of \$90,000 under Prop 84, awarded by the State Water Resources Control Board (SWRCB). The District is seeking 25% Federal Grants for the project budget total and construction of the CCT expansion will be contingent on acquiring these funds.

Operations Impact: Normal maintenance.

Project Spending Plan

Project Phase	Previous Spending	FY 17/18	FY 18/19	FY 19/20	FY 20/21	FY 21/22 & Thereafter	Total
Planning	\$160,000	\$1,000	\$1,000	\$1,000	\$1,000	\$1,000	\$165,000
Design						\$350,000	\$350,000
Construction						\$4,300,000	\$4,300,000
Total	\$160,000	\$1,000	\$1,000	\$1,000	\$1,000	\$4,651,000	\$4,815,000

FY 2017/18 Budget Request - \$2,865,000

Estimated Project Timeline

Project Approval	Planning		Design		Construction		Completion
	Begin	End	Begin	End	Begin	End	
Jul 2015	Apr 2016	Jun 2022	Jul 2022	Oct 2023	Nov 2023	Sep 2024	Sep 2024

Capital Improvement Program Montiel Gravity Outfall

Description: This project involves the study and potential construction of approximately 7,720 feet of new 10-inch gravity sewer main underneath SR-78 from the Montiel Lift Station to Mission Road and continuing on Mission Road, Andreasen Drive, and Simpson Way to Hale Avenue. This will effectively reroute the sewer that is currently pumped from the Montiel Lift Station to the City of Escondido’s sewer system in Mission Road just east of Nordahl Road.



Project Manager: Rob Scholl

Department: Engineering

Project: 2016100003

Funding Source: 45% Fund 210 – Sewer Replacement
55% Fund 220 – Sewer Capacity

Work Order: 165996

Comments: To offset the Montiel Lift Station Replacement, the Montiel Lift Station Force Main Replacement, and the Nordahl Shopping Center Sewer Replacement projects as identified in the Master Plan and consistent with the District’s Strategic Plan – Strategic Focus Area 1.4, staff is investigating the possibility of constructing a gravity sewer outfall to the City of Escondido’s sewer system. Upon entering an agreement with the City of Escondido for a new gravity sewer connection, which may include possible reimbursement to the District, the Montiel Lift Station Replacement and the Montiel Lift Station Force Main Replacement will be eliminated and the Nordahl Shopping Center Sewer Replacement project may be eliminated. These projects amount to approximately \$4,700,000 to construct and \$25,000 annually to operate and maintain.

Operations Impact: Annual and routine sewer pipeline maintenance.

Project Spending Plan

Project Phase	Previous Spending	FY 17/18	FY 18/19	FY 19/20	FY 20/21	FY 21/22 & Thereafter	Total
Planning	\$145,000	\$260,000	\$20,000				\$425,000
Design		\$120,000	\$100,000				\$220,000
Construction			\$2,440,000	\$1,640,000			\$4,080,000
Total	\$145,000	\$380,000	\$2,560,000	\$1,640,000	\$0	\$0	\$4,725,000

FY 2017/18 Budget Request - \$2,975,000

Estimated Project Timeline

Project Approval	Planning		Design		Construction		Completion
	Begin	End	Begin	End	Begin	End	
Jul 2015	Feb 2016	Feb 2018	Mar 2018	Nov 2018	Dec 2018	Nov 2019	Nov 2019

Capital Improvement Program Meadowlark Tank No. 3

Description: This existing Meadowlark Tank site is comprised of one 1.25 million gallon tank and a second 2.75 million gallon tank. The 1.25 million gallon tank will be demolished and replaced by a new 2.8 million gallon tank. As part of this project, grading for a future 2.8 million gallon Meadowlark Tank No. 4 will also occur. Site improvements include grading and clearing, landscaping, and installation of new 20” and 16” inlet/outlet piping.



Project Manager: Jason Hubbard

Department: Engineering

Project: 71084

Funding Source: 35% Fund 110 – Water Replacement
65% Fund 120 – Water Capacity

Work Order: 71084

Comments: The site was master planned during the 76-1 Assessment District to accommodate three tanks total. The final tank is not expected to be needed until 2021. At build-out, the Meadowlark Tanks will provide a total storage capacity of 8.35 million gallons.

Operations Impact: The project will increase capacity at the site by 1.55 million gallons with the construction of the new tank. Daily monitoring of water levels and conditions at the tank site is expected.

Project Spending Plan

Project Phase	Previous Spending	FY 17/18	FY 18/19	FY 19/20	FY 20/21	FY 21/22 & Thereafter	Total
Planning	\$123,000						\$123,000
Design	\$377,000		\$41,000				\$418,000
Construction			\$3,011,000	\$1,000,000			\$4,011,000
Total	\$500,000	\$0	\$3,052,000	\$1,000,000	\$0	\$0	\$4,552,000

FY 2017/18 Budget Request - \$0

Estimated Project Timeline

Project Approval	Planning		Design		Construction		Completion
	Begin	End	Begin	End	Begin	End	
Jul 2003	Aug 2003	Mar 2004	Apr 2004	Jun 2013	Nov 2018	Sep 2019	Sep 2019

Capital Improvement Program Mountain Belle Pump Station

Description: This project involves the construction of three 1,000 gallon-per-minute pumps and 125 horsepower motors, along with all corresponding electronics, within a new building next to the existing Mountain Belle Reservoir. Approximately 1,800 feet of 16-inch connector pipe from the pump station to an existing 10” pipeline in the North Twin Oaks (1330’) Pressure Zone will also be installed.



Project Manager: Jason Hubbard

Department: Engineering

Project: 71219

Funding Source: 100% Fund 120 – Water Capacity

Comments: The Mountain Belle Pump Station is intended to serve as a completely redundant water supply to the new North Twin Oaks (1330’) pump station. It will be sized to meet ultimate build-out demands in the North Twin Oaks 1330’ Pressure Zone, the 1059’ Pressure Zone, and the North 1228’ Pressure Zone. A pad for this pump station has already been placed next to the Mountain Belle Reservoir (see picture above).

Operations Impact: Redundant pumping capacity to the North Twin Oaks Pressure Zone. Daily, routine monitoring and inspections of the pump station is expected, as are regular maintenance efforts and some infrequent repair work.

Project Spending Plan

Project Phase	Previous Spending	FY 17/18	FY 18/19	FY 19/20	FY 20/21	FY 21/22 & Thereafter	Total
Planning	\$10,000						\$10,000
Design	\$90,000					\$310,000	\$400,000
Construction						\$3,450,000	\$3,450,000
Total	\$100,000	\$0	\$0	\$0	\$0	\$3,760,000	\$3,860,000

FY 2017/18 Budget Request - \$0

Estimated Project Timeline

Project Approval	Planning		Design		Construction		Completion
	Begin	End	Begin	End	Begin	End	
Jul 2006	Aug 2006	Feb 2007	Feb 2007	Apr 2022	May 2022	May 2023	May 2023

Capital Improvement Program Rock Springs Sewer Replacement

Description: Abandonment and/or removal of approximately 2,500 feet of 8” VCP sewer main and 10 manholes within Rock Springs Road and adjacent greenbelt. This project will bring relief to a section of existing sewer pipe within a greenbelt drainage area that is currently operating beyond its design limits.

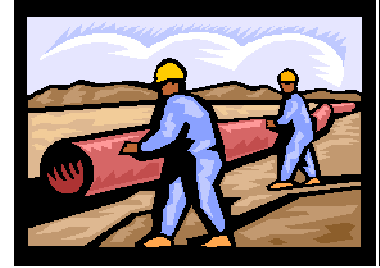

Project Manager: Jason Hubbard

Department: Engineering

Project: 90003

Funding Source: 45% Fund 210 – Sewer Replacement

Work Order: 090003

55% Fund 220 – Sewer Capacity

Comments: The 2500' of existing vitrified clay pipe (VCP) will be replaced by 2,700 feet of new PVC sewer main, including 16 new manholes and the rehabilitation of 4 existing manholes. This will eliminate an existing surcharging condition in the District’s collection system between Woods Dr. and Hannigans Way within a greenbelt drainage area south of Rock Springs Rd. The 2008 Master Plan has identified this upgrade as project SP-5.

Operations Impact: Less inflow and infiltration into the collection system; reduced risk of sewer spilling. Annual, routine sewer pipeline maintenance is expected with the completion of this project.

Project Spending Plan

Project Phase	Previous Spending	FY 17/18	FY 18/19	FY 19/20	FY 20/21	FY 21/22 & Thereafter	Total
Planning	\$50,000						\$50,000
Design	\$475,000						\$475,000
Construction		\$2,640,000					\$2,640,000
Total	\$525,000	\$2,640,000	\$0	\$0	\$0	\$0	\$3,165,000

FY 2017/18 Budget Request - \$705,000

Estimated Project Timeline

Project Approval	Planning		Design		Construction		Completion
	Begin	End	Begin	End	Begin	End	
Jul 2008	Jul 2008	Jan 2010	Feb 2010	Jul 2017	Aug 2017	Feb 2018	Feb 2018

**Capital Improvement Program
Encina Wastewater Authority FY 16/17**

Description: The District is a member agency of the Encina Wastewater Authority (EWA). The District shares in the cost of planned asset replacements and capital acquisitions.

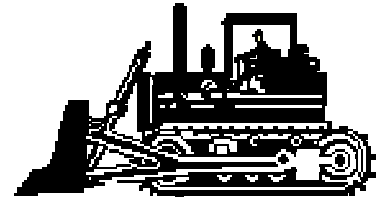

Project Manager: Tom Scaglione

Department: General Manager

Project: 2017100001

Funding Source: 100% Fund 210 – Sewer Replacement

Comments: These miscellaneous Encina Wastewater Authority capital projects are budgeted each year based on the District’s 22.4% ownership share.

Operations Impact: No significant increase in costs or changes in efficiencies are anticipated from this project

Project Spending Plan

Project Phase	Previous Spending	FY 17/18	FY 18/19	FY 19/20	FY 20/21	FY 21/22 & Thereafter	Total
Planning							
Design							
Construction	\$1,384,000	\$650,000					\$2,034,000
Total	\$1,384,000	\$650,000	\$0	\$0	\$0	\$0	\$2,034,000

FY 2017/18 Budget Request - (\$835,000)

Estimated Project Timeline

Project Approval	Planning		Design		Construction		Completion
	Begin	End	Begin	End	Begin	End	
Jul 2009							Jun 2017

Capital Improvement Program
MRF: On-site Generation of Sodium Hypochlorite

Description: Replace the use of chlorine gas at the Meadowlark Water Reclamation Facility with onsite generation of sodium hypochlorite (bleach).



Project Manager: Ed Pedrazzi

Department: Engineering

Project: 2017100002

Funding Source: 100% Fund 210 – Sewer Replacement

Comments: The Meadowlark Water Reclamation Facility (MRF) currently uses 100% chlorine gas as a disinfectant in order to meet State regulations for reclaimed water. Chlorine gas is an acute hazard that presents a danger to District staff and the increasing number of residents in the immediate area. Use of this gas requires the District to maintain several expensive State and Federal safety programs, equipment, and a Hazardous Materials response team; requiring a considerable amount of staff time. The onsite generation of sodium hypochlorite removes the acute hazard of chlorine gas and replaces it with a mild form of bleach (0.8%) that removes the District’s requirement to maintain the extensive safety programs for that site. Use of the bleach will not require a hazardous materials response in the event of a leak.

Operations Impact: Removal of an acute hazard. Reduction in regulatory requirements and staff time at the Meadowlark Reclamation Facility. Economic benefit of no longer needing to import chlorine gas. Routine maintenance.

Project Spending Plan

Project Phase	Previous Spending	FY 17/18	FY 18/19	FY 19/20	FY 20/21	FY 21/22 & Thereafter	Total
Planning			\$50,000				\$50,000
Design			\$200,000				\$200,000
Construction			\$50,000	\$1,700,000			\$1,750,000
Total	\$0	\$0	\$300,000	\$1,700,000	\$0	\$0	\$2,000,000

FY 2017/18 Budget Request - \$0

Estimated Project Timeline

Project Approval	Planning		Design		Construction		Completion
	Begin	End	Begin	End	Begin	End	
Jul 2016	Jul 2018	Sep 2018	Oct 2018	May 2019	Jun 2019	Nov 2019	Aug 2019

Capital Improvement Program Richland Invert Replacement

Description: This project calls for the replacement of the existing 100-foot wastewater siphon pipeline that travels under San Marcos Creek from the Diamond Environmental Services parking lot south of Mission Road to the 18-inch Richland Interceptor. The existing 8-inch and 10-inch pipelines will be replaced with either a new 15-inch siphon to be located at the existing pipelines' location or by a new 15-inch gravity pipeline in Mission Road and a new crossing further to the west.



Project Manager: Jason Hubbard

Department: Engineering

Project: 2012100002

Funding Source: 100% Fund 210 – Sewer Replacement

Work Order: 123749

Comments: The existing 8-inch and 10-inch invert pipelines were installed over 27 years ago and were originally designed to be temporary. Because of their size restrictions, they surcharge upstream gravity pipelines during peak flows. In addition, recent inspections by the District's collections crew have revealed damage to the existing pipe. This project crosses underneath San Marcos Creek, and staff anticipates environmental wetland permitting requirements. The 2008 Master Plan has identified this replacement as project SP-10.

Operations Impact: The project increases sewage handling capacity in the collections system and solves an existing sewer surcharge issue during daily peak and wet weather events. Annual, routine sewer pipeline maintenance is expected with the completion of this project.

Project Spending Plan

Project Phase	Previous Spending	FY 17/18	FY 18/19	FY 19/20	FY 20/21	FY 21/22 & Thereafter	Total
Planning	\$13,000	\$12,000					\$25,000
Design			\$150,000				\$150,000
Construction			\$150,000	\$1,160,000			\$1,310,000
Total	\$13,000	\$12,000	\$300,000	\$1,160,000	\$0	\$0	\$1,485,000

FY 2017/18 Budget Request - \$350,000

Estimated Project Timeline

Project Approval	Planning		Design		Construction		Completion
	Begin	End	Begin	End	Begin	End	
Jun 2011	Apr 2012	Jul 2018	Jul 2018	Apr 2019	May 2019	Jan 2020	Jan 2020

Capital Improvement Program Land Outfall Clearing & Access Road

Description: The Land Outfall is located within easements for a significant portion of its length where it runs within the Encina Creek riparian area parallel to Palomar Airport Road in Carlsbad. The District is attempting to remove the overgrown vegetation within the easement and construct a drivable path to access the pipeline for maintenance and emergencies. Streambed alteration permitting and habitat mitigation are the major challenges associated with this project.

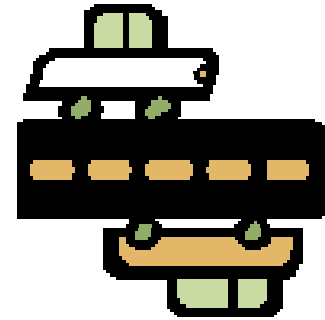

Project Manager: Rob Scholl

Department: Engineering

Project: 71177

Funding Source: 100% Fund 210 – Sewer Replacement

Comments: Clearing for the access road impacts an estimated 1 acre of designated wetland at a cost of approximately \$600,000/acre. The Land Outfall is owned by the District and shares capacity in this stretch with the cities of Carlsbad and Vista and the Buena Sanitation District. The joint agreement requires them to pay their proportionate share of this maintenance activity. Approximate responsibility of cost:

- Buena Sanitation District - 68%
- City of Carlsbad - 12%
- Vallecitos Water District - 20%

Operations Impact: Routine maintenance

Project Spending Plan

Project Phase	Previous Spending	FY 17/18	FY 18/19	FY 19/20	FY 20/21	FY 21/22 & Thereafter	Total
Planning	\$250,000	\$600,000					\$850,000
Design	\$40,000						\$40,000
Construction	\$60,000	\$200,000					\$260,000
Total	\$350,000	\$800,000	\$0	\$0	\$0	\$0	\$1,150,000

FY 2017/18 Budget Request - \$205,000

Estimated Project Timeline

Project Approval	Planning		Design		Construction		Completion
	Begin	End	Begin	End	Begin	End	
Jul 2006	Jul 2006	Jun 2017	Feb 2008	Jun 2017	Jul 2008	Jun 2018	Jun 2018

Capital Improvement Program Water and Sewer Master Plan

Description: Master Plans are typically updated every 5 years because project priorities shift and land use agencies approve zoning changes in the Districts’ boundaries. Since the adoption of the 2008 Master Plan, VWD’s per capita water and wastewater demands have declined due to drought and the recession, and the City of San Marcos has approved several developments with zoning changes. VWD has also inked contracts for the purchase of treated water from the Olivenhain Water District and desalinated water directly from Poseidon Resources – both of which will likely shift capital project priorities. These reasons will trigger the need for a master plan update. This item is part of the VWD Strategic Plan – Strategic Focus Areas 1.3 and 6.4

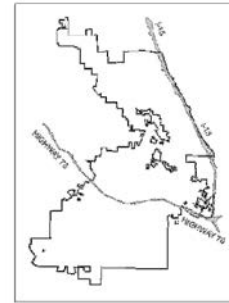

Project Manager: Rob Scholl

Department: Engineering

Project: 2014100003

Funding Source: 50% Fund 120 – Water Capacity
50% Fund 220 – Sewer Capacity

Comments: An Environmental Impact Report will be prepared in conjunction with the master plan update. This document will detail the impacts, at a programmatic level, that the master plan projects may create on the community and the environment. The District’s water and wastewater models will also be updated during this master plan update, and a water supply planning section that will analyze expansion of recycled water use will be included.

Operations Impact: Will identify new projects that will likely require frequent maintenance activities by Operations.

Project Spending Plan

Project Phase	Previous Spending	FY 17/18	FY 18/19	FY 19/20	FY 20/21	FY 21/22 & Thereafter	Total
Planning	\$950,000	\$100,000					\$1,050,000
Design							
Construction							
Total	\$950,000	\$100,000	\$0	\$0	\$0	\$0	\$1,050,000

FY 2017/18 Budget Request - \$0

Estimated Project Timeline

Project Approval	Planning		Design		Construction		Completion
	Begin	End	Begin	End	Begin	End	
Jul 2013	Jul 2013	Dec 2017					Dec 2017

Capital Improvement Program Old Questhaven Sewer Replacement

Description: Installation of 1400 feet of 24” PVC sewer main in the old Questhaven Road right-of-way, along with 6 new manholes; abandonment of 935 feet of 21” VCP and 255 feet of 21” PVC temporary sewer pipe in the old Questhaven Road right-of-way; abandonment of 1470 feet of 24” DIP temporary sewer pipe in Rancho Santa Fe Road.



Project Manager: Jason Hubbard

Department: Engineering

Project: 80001

Funding Source: 77% Fund 210 – Sewer Replacement
23% Fund 220 – Sewer Capacity

Comments: This project will replace a section of existing temporary sewer pipe in the old Questhaven Road right-of-way. The new pipe section will be higher in elevation to connect to the permanent pipeline in Rancho Santa Fe Road and allow the temporary pipeline in both old Rancho Santa Fe Road and old Questhaven Road right-of-way and San Marcos Creek to be abandoned.

Operations Impact: Less inflow and infiltration into the collection system; abandonment of a temporary sewer pipeline. Annual, routine sewer pipeline maintenance is expected with the completion of this project.

Project Spending Plan

Project Phase	Previous Spending	FY 17/18	FY 18/19	FY 19/20	FY 20/21	FY 21/22 & Thereafter	Total
Planning	\$1,000					\$9,000	\$10,000
Design						\$75,000	\$75,000
Construction						\$750,000	\$750,000
Total	\$1,000	\$0	\$0	\$0	\$0	\$834,000	\$835,000

FY 2017/18 Budget Request - \$0

Estimated Project Timeline

Project Approval	Planning		Design		Construction		Completion
	Begin	End	Begin	End	Begin	End	
Jul 2007	Jul 2007	Aug 2021	Sep 2021	Dec 2022	Jan 2023	Apr 2024	Apr 2024

Capital Improvement Program Expansion of the Men’s Locker Room in Building B

Description: Expansion of the men’s locker room in Building B for Operations & Maintenance staff.



Project Manager: Ed Pedrazzi

Department: Operations and Maintenance

Project: 2016100005

Funding Source: 51% Fund 110 – Water Replacement
49% Fund 210 - Sewer Replacement

Comments: The Operations & Maintenance (O&M) men’s locker room in Building B is no longer large enough to accommodate the number of employees utilizing it. The expansion will double the size of the locker room. The number of lockers, showers, sinks and urinals will also be doubled. This will provide adequate space for O&M staff to clean up and change uniforms.

Operations Impact: Routine maintenance.

Project Spending Plan

Project Phase	Previous Spending	FY 17/18	FY 18/19	FY 19/20	FY 20/21	FY 21/22 & Thereafter	Total
Planning							
Design	\$140,000						\$140,000
Construction		\$670,000					\$670,000
Total	\$140,000	\$670,000	\$0	\$0	\$0	\$0	\$810,000

FY 2017/18 Budget Request - \$235,000

Estimated Project Timeline

Project Approval	Planning		Design		Construction		Completion
	Begin	End	Begin	End	Begin	End	
Jul 2015			Aug 2016	Apr 2017	Jul 2017	Jan 2018	Jan 2018

Capital Improvement Program Audiovisual Upgrade

Description: Various audiovisual improvements to upgrade technology in the board room and several conference rooms and the training room.

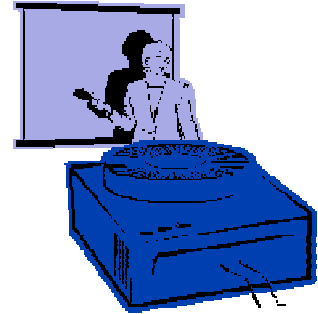

Project Manager: Karla Fisher

Department: Information Technology

Project: 2015100002

Funding Source: 51% Fund 110 – Water Replacement
49% Fund 210 - Sewer Replacement

Comments: The audiovisual systems in the District Board Room, Training Room, and Conference Rooms have become outdated and were installed with the construction of Building A. This project will upgrade existing technology to accommodate televised Board of Director meetings and create a consistency between conference rooms and the training room. Phase I: Select a design consultant to determine upgrade requirements, design the audiovisual systems, and approximate cost. The design consultant will create RFP, assist with selection of a contractor, and oversee project through testing, training and completion. Phase II: Select contractor to implement design from Phase I.

Operations Impact: Routine Maintenance

Project Spending Plan

Project Phase	Previous Spending	FY 17/18	FY 18/19	FY 19/20	FY 20/21	FY 21/22 & Thereafter	Total
Planning							
Design	\$45,000						\$45,000
Construction	\$455,000	\$250,000					\$705,000
Total	\$500,000	\$250,000	\$0	\$0	\$0	\$0	\$750,000

FY 2017/18 Budget Request - \$250,000

Estimated Project Timeline

Project Approval	Planning		Design		Construction		Completion
	Begin	End	Begin	End	Begin	End	
	Jul 2014	Jun 2017					Jun 2018

Capital Improvement Program City of San Marcos Joint Projects

Description: This amount is set-aside to cover services rendered in conjunction with various City of San Marcos projects involving District infrastructure per the District/City of San Marcos Cost Sharing Agreement dated March 31, 2009. This includes District staff time involved in inspection and project management, as well as reimbursements to the City for District infrastructure relocations and adjustments.



Project Manager: Rob Scholl

Department: Engineering

Project: 90007

Funding Source: See Below

Comments:

Project :	Amount :	Source :
Rancho Santa Fe Rd Resurfacing	\$85,000	Water/Sewer 55% / 45%
Discovery St Improvements	\$550,000	Water/Sewer 90% / 10%
Misc. Relocations/Adjustments	\$70,000	Water/Sewer 75% / 25%
Armorlite Dr	\$35,000	Water/Sewer 80% / 20%
Discovery/Bent/Via Vera Cruz	\$10,000	Water/Sewer 100%
Total	\$750,000	

These projects are in conjunction with the City's Capital Improvement Plan.

Operations Impact: Normal maintenance for infrastructure.

Project Spending Plan

Project Phase	Previous Spending	FY 17/18	FY 18/19	FY 19/20	FY 20/21	FY 21/22 & Thereafter	Total
Planning							
Design							
Construction	\$90,000	\$650,000		\$10,000			\$750,000
Total	\$90,000	\$650,000	\$0	\$10,000	\$0	\$0	\$750,000

FY 2017/18 Budget Request - \$80,000

Estimated Project Timeline

Project Approval	Planning		Design		Construction		Completion
	Begin	End	Begin	End	Begin	End	
						Jan 2020	Jan 2020

Capital Improvement Program High Point Pipeline

Description: Approximately 2,800 feet of 12” PVC potable water pipeline is proposed to connect the 1625 High Point Pressure Zone to the 1567 Wulff Pressure Zone. This project also includes the construction of a pressure reducing valve to the 1567 Wulff Pressure Zone’s hydraulic grade line. The High Point development is responsible for installation of an 8” pipeline as part of its development conditions, and the District will reimburse the developer for upsizing the pipeline to 12”.

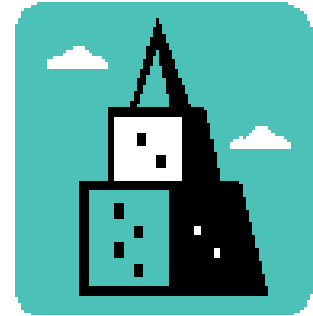

Project Manager: Rob Scholl

Department: Engineering

Project: 2013100006

Funding Source: 100% Fund 120 – Water Capacity

Comments: This pipeline provides an auxiliary feed from the 1625 High Point Pressure Zone to the 1567 Wulff Pressure Zone. And with the completion and acceptance of the High Point Hydro-pneumatic Pump Station, the District will have some limited ability to transfer potable water from the 920 Pressure Zone to the higher northern pressure zones that does not currently exist. The 2008 Master Plan has identified this pipeline as Project P-43.

Operations Impact: Annual and routine potable water pipeline maintenance.

Project Spending Plan

Project Phase	Previous Spending	FY 17/18	FY 18/19	FY 19/20	FY 20/21	FY 21/22 & Thereafter	Total
Planning							
Design							
Construction			\$700,000				\$700,000
Total	\$0	\$0	\$700,000	\$0	\$0	\$0	\$700,000

FY 2017/18 Budget Request - \$0

Estimated Project Timeline

Project Approval	Planning		Design		Construction		Completion
	Begin	End	Begin	End	Begin	End	
Jul 2012					Oct 2018	Jun 2019	Jun 2018

Capital Improvement Program District-wide Valve Replacement Program

Description: Replace broken or leaking valves throughout the District.



Project Manager: Kevin Antcil

Department: Construction

Project: 2016100004

Funding Source: 100% Fund 110 – Water Replacement

Comments: The valve crew has discovered many broken valves requiring replacement. This project targets 20 valves per year over four years.

Operations Impact: Routine maintenance.

Project Spending Plan

Project Phase	Previous Spending	FY 17/18	FY 18/19	FY 19/20	FY 20/21	FY 21/22 & Thereafter	Total
Planning							
Design							
Construction	\$350,000	\$175,000	\$175,000				\$700,000
Total	\$350,000	\$175,000	\$175,000	\$0	\$0	\$0	\$700,000

FY 2017/18 Budget Request - \$0

Estimated Project Timeline

Project Approval	Planning		Design		Construction		Completion
	Begin	End	Begin	End	Begin	End	
Jul 2015					Jul 2015	Jul 2019	Jun 2019

Capital Improvement Program Northwest Lake San Marcos Sewer Replacement and Relining Project

Description: This project involves the replacement of approximately 1000 feet of existing 8-inch VCP sewer pipeline with new 8-inch PVC pipe. In addition, approximately 750 feet of adjacent VCP pipeline will be lined to extend its useful life. This item is part of the VWD Strategic Plan – Strategic Focus Area 1.4



Project Manager: Jason Hubbard

Department: Engineering

Project: 2014100002

Funding Source: 100% Fund 210 – Sewer Replacement

Work Order: 167352

Comments: The sewer pipeline in the northwest Lake San Marcos area is being compromised due to lime leaching into the pipe. This pipe was installed between 1964 and 1971 and is reaching the end of its useful life. While lime damage warrants replacement of most of the pipe in this area, some pipeline can be relined instead to extend its life.

Operations Impact: Annual and routine sewer pipeline maintenance.

Project Spending Plan

Project Phase	Previous Spending	FY 17/18	FY 18/19	FY 19/20	FY 20/21	FY 21/22 & Thereafter	Total
Planning	\$2,000	\$3,000					\$5,000
Design		\$75,000	\$30,000				\$105,000
Construction			\$495,000				\$495,000
Total	\$2,000	\$78,000	\$525,000	\$0	\$0	\$0	\$605,000

FY 2017/18 Budget Request - \$0

Estimated Project Timeline

Project Approval	Planning		Design		Construction		Completion
	Begin	End	Begin	End	Begin	End	
Jul 2013	Jul 2016	Dec 2017	Jan 2018	Jan 2019	Feb 2019	Aug 2019	Feb 2018

Capital Improvement Program Asset Management Replacement Schedule

Description: Create a prioritized Asset/Infrastructure replacement schedule for the District Facilities. This item is part of the VWD Strategic Plan – Strategic Focus Area 1.2

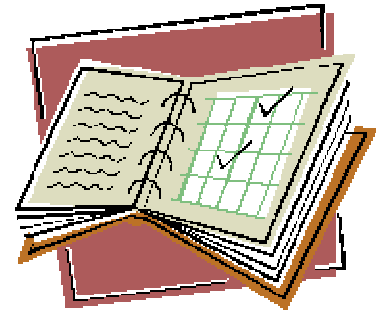

Project Manager: James Gumpel

Department: Engineering

Project: 2014100004

Funding Source: 50% Fund 110 – Water Replacement
50% Fund 210 – Sewer Replacement

Comments: The District’s infrastructure is aging and proper planning requires an understanding of when, where, and how much replacing that infrastructure will cost. Proper preventative maintenance helps insure the District obtains the maximum beneficial life out of its infrastructure. The District has already taken steps towards this by implementing a computerized maintenance management system (CMMS) also known as Maximo to implement and track preventative, corrective, and emergency maintenance/repairs on all assets or infrastructure. This project will take the CMMS information and prioritize a replacement schedule as well as cost over the expected life of all assets/infrastructure.

Operations Impact:

Project Spending Plan

Project Phase	Previous Spending	FY 17/18	FY 18/19	FY 19/20	FY 20/21	FY 21/22 & Thereafter	Total
Planning		\$200,000	\$200,000	\$200,000			\$600,000
Design							
Construction							
Total	\$0	\$200,000	\$200,000	\$200,000	\$0	\$0	\$600,000

FY 2017/18 Budget Request - \$0

Estimated Project Timeline

Project Approval	Planning		Design		Construction		Completion
	Begin	End	Begin	End	Begin	End	
Jul 2013	Jul 2017	Jun 2020					Jun 2020

Capital Improvement Program Vulnerability Assessment Improvements

Description: The District completed the Vulnerability Assessment as required by the Department of Homeland Security. Recommended improvements were identified and being phased in. Fiscal year 2014/15 purchases are for security devices and a 500 kW generator.



Project Manager: Jerome Janus

Department: Engineering - Safety

Project: 71126

Funding Source: 51% Fund 110 – Water Replacement
49% Fund 210 - Sewer Replacement

Comments: Implementing safety measures to mitigate vulnerabilities is an on-going process. Due to the highly confidential and sensitive nature of the assessment findings, specific improvements are not defined in this document. Security measures are implemented with the most vulnerable areas addressed first.

Operations Impact: Continual review of measures implemented and discovery of unidentified areas.

Project Spending Plan

Project Phase	Previous Spending	FY 17/18	FY 18/19	FY 19/20	FY 20/21	FY 21/22 & Thereafter	Total
Planning							
Design							
Construction	\$336,700	\$111,000					\$447,700
Total	\$336,700	\$111,000	\$0	\$0	\$0	\$0	\$447,700

FY 2017/18 Budget Request - \$0

Estimated Project Timeline

Project Approval	Planning		Design		Construction		Completion
	Begin	End	Begin	End	Begin	End	
Jul 2004							

Capital Improvement Program North Vista Pressure Reducing Station Upgrade

Description: Upgrade the existing North Vista Pressure Reducing Station with electrical power and bring it up to current standards.

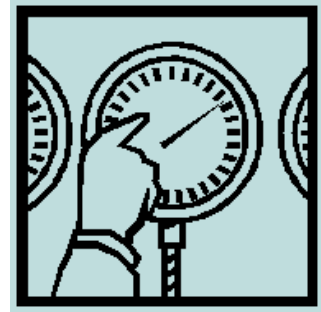

Project Manager: Jason Hubbard

Department: Water Operations

Project: 2014100008

Funding Source: 100% Fund 110 – Water Replacement

Work Order: 133165

Comments: North Vista Pressure Reducing Station is one of the oldest in the District. VWD does not have a SCADA system at this site due to lack of electrical power. The station is one of the few remaining sites in the District without SCADA monitoring. The funds requested are for design and construction to upgrade the pressure reducing station to meet all current standards, including electrical power and SCADA monitoring equipment.

Operations Impact: Routine Maintenance.

Project Spending Plan

Project Phase	Previous Spending	FY 17/18	FY 18/19	FY 19/20	FY 20/21	FY 21/22 & Thereafter	Total
Planning							
Design	\$60,000	\$2,000					\$62,000
Construction		\$303,000					\$303,000
Total	\$60,000	\$305,000	\$0	\$0	\$0	\$0	\$365,000

FY 2017/18 Budget Request - \$123,000

Estimated Project Timeline

Project Approval	Planning		Design		Construction		Completion
	Begin	End	Begin	End	Begin	End	
Jul 2013			Jul 2013	Aug 2017	Sep 2017	Nov 2017	Nov 2017

Capital Improvement Program Lift Station 1 Wet Well Room Repairs

Description: The room above the Lift Station No.1 wet well is in need of repairs due to the corrosion from the concentration of excessive hydrogen sulfide gases.



Project Manager: Jason Hubbard

Department: Engineering

Project: 2017100004

Funding Source: 100% Fund 210 – Sewer Replacement

Comments: To control noxious odors at the lift station, the main entrance to the wet well room was enclosed and carbon scrubbers added. The beneficial reduction in odors has had the resultant side effect of increased corrosion to all the metal, concrete, and masonry block surfaces within the room, including the ceiling, floors, walls, door jambs, and various fixtures due to the higher concentration of hydrogen sulfide gases. A combination of repairs, including polyurethane and epoxy coatings to the various surfaces and reinforcement of the ceiling, will prevent further deterioration.

Operations Impact: Reduced risk of the loss of structural integrity for the building and increased safety. Reduced maintenance.

Project Spending Plan

Project Phase	Previous Spending	FY 17/18	FY 18/19	FY 19/20	FY 20/21	FY 21/22 & Thereafter	Total
Planning							
Design	\$43,000						\$43,000
Construction	\$37,000	\$215,000					\$252,000
Total	\$80,000	\$215,000	\$0	\$0	\$0	\$0	\$295,000

FY 2017/18 Budget Request - \$0

Estimated Project Timeline

Project Approval	Planning		Design		Construction		Completion
	Begin	End	Begin	End	Begin	End	
Jul 2016	Jul 2016	Jul 2016	Jul 2016	Apr 2017	May 2017	Sep 2017	Sep 2017

Capital Improvement Program Rock Springs Valve Replacement

Description: Replace the existing 12 inch and 14 inch valve cluster at Rock Springs Road and Bennet Avenue and associated piping. The valves are non-operational and the nearby pipeline has failed in recent years

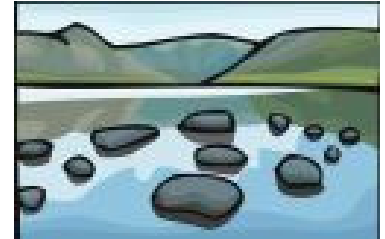

Project Manager: Jason Hubbard

Department: Engineering

Project: 2016100007

Funding Source: 100% Fund 110 – Water Replacement

Comments: This project will allow proper control of the water system and prevent further failures.

Operations Impact: The valves are non-operational. Operations and maintenance repair costs will be minimized at this location.

Project Spending Plan

Project Phase	Previous Spending	FY 17/18	FY 18/19	FY 19/20	FY 20/21	FY 21/22 & Thereafter	Total
Planning		\$15,000					\$15,000
Design			\$60,000				\$60,000
Construction			\$160,000	\$30,000			\$190,000
Total	\$0	\$15,000	\$220,000	\$30,000	\$0	\$0	\$265,000

FY 2017/18 Budget Request - \$15,000

Estimated Project Timeline

Project Approval	Planning		Design		Construction		Completion
	Begin	End	Begin	End	Begin	End	
Jul 2015	Apr 2018	Jun 2018	Jul 2018	Mar 2019	Apr 2019	Aug 2019	Aug 2019

Capital Improvement Program South Vista Pressure Reducing Station Upgrade

Description: Replace the existing South Vista Pressure Reducing Station with a larger vault and bring it up to current standards.

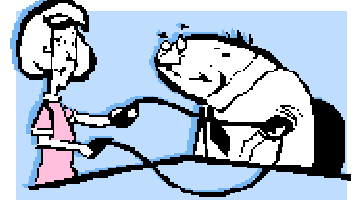

Project Manager: Jason Hubbard

Department: Water Operations

Project: 2014100007

Funding Source: 100% Fund 110 – Water Replacement

Work Order: 133166

Comments: South Vista Pressure Reducing Station is one of the oldest in the District. We do not have a SCADA system at this site due to lack of electrical power. The pressure station vault is extremely small with minimal working space. The station is one of the few remaining sites in the District without SCADA monitoring. The funds requested are for design and construction to replace the pressure reducing station with a new vault that meets all current standards, including electrical power and SCADA monitoring equipment.

Operations Impact: Routine Maintenance.

Project Spending Plan

Project Phase	Previous Spending	FY 17/18	FY 18/19	FY 19/20	FY 20/21	FY 21/22 & Thereafter	Total
Planning							
Design	\$60,000	\$3,000					\$63,000
Construction		\$192,000					\$192,000
Total	\$60,000	\$195,000	\$0	\$0	\$0	\$0	\$255,000

FY 2017/18 Budget Request - \$21,000

Estimated Project Timeline

Project Approval	Planning		Design		Construction		Completion
	Begin	End	Begin	End	Begin	End	
Jul 2011			Jul 2013	Aug 2017	Sep 2017	Nov 2017	Nov 2017

Capital Improvement Program Fire Services - Backflow Preventer Upgrades

Description: Replace single-check backflow prevention systems with double-check systems on fire services.



Project Manager: Kevin Anttil

Department: Construction

Project: 2017100005

Funding Source: 100% Fund 110 – Water Replacement

Comments: The District is responsible for several fire service backflow preventers in the distribution system that were installed prior to new District standards being adopted. The single-check backflow preventers that were installed are no longer an acceptable device and some have failed due to corrosion from being installed in an underground vault. The Construction department will replace 5 systems each year with an approved double-check backflow prevention system and bring the services above ground.

Operations Impact: Enhanced backflow prevention. Routine maintenance.

Project Spending Plan

Project Phase	Previous Spending	FY 17/18	FY 18/19	FY 19/20	FY 20/21	FY 21/22 & Thereafter	Total
Planning							
Design							
Construction	\$50,000	\$50,000	\$50,000	\$50,000	\$50,000		\$250,000
Total	\$50,000	\$50,000	\$50,000	\$50,000	\$50,000	\$0	\$250,000

FY 2017/18 Budget Request - \$0

Estimated Project Timeline

Project Approval	Planning		Design		Construction		Completion
	Begin	End	Begin	End	Begin	End	

Capital Improvement Program Via Vera Cruz Tank Hill Stabilization

Description: A side slope adjacent to the Via Vera Cruz Tank requires slope stabilization treatment.



Project Manager: Jason Hubbard

Department: Engineering

Project: 2016100014

Funding Source: 100% Fund 110 – Water Replacement

Work Order: 162901

Comments: A portion of the existing slope adjacent to the Visa Vera Cruz Tank on District property is failing due to steep terrain and material composition. The foundation of a property line fence is being eroded and exposed and material washes down to the tank elevation. Routine clean-up of the area is done and falling rocks threaten to damage the tank. This project will apply a mesh or tensioned slope stabilization system to approximately 2200 SF of steep slope to prevent further failures and/or a debris barrier along a portion of the perimeter to catch failing rocks. Repairs to the property line fence will also be performed and landscaping repairs may be necessary.

Operations Impact: Reduced risk of damage to the tank from falling rocks. Eliminate clean-up of the area from debris. Maintain security of property with intact fence. Annual and routine monitoring of the slope.

Project Spending Plan

Project Phase	Previous Spending	FY 17/18	FY 18/19	FY 19/20	FY 20/21	FY 21/22 & Thereafter	Total
Planning							
Design	\$8,000	\$10,000					\$18,000
Construction		\$127,000					\$127,000
Total	\$8,000	\$137,000	\$0	\$0	\$0	\$0	\$145,000

FY 2017/18 Budget Request - \$10,000

Estimated Project Timeline

Project Approval	Planning		Design		Construction		Completion
	Begin	End	Begin	End	Begin	End	
Jul 2015	Jan 2016	Mar 2016	Apr 2016	Mar 2018	Apr 2018	Jun 2018	Jun 2018

Capital Improvement Program Fulton Road and NCTD Sewer Line Rehabilitation

Description: Two sewer line sections need rehabilitation and/or replacement to lengthen the life of the aging main line.



Project Manager: Jason Hubbard

Department: Engineering

Project: 2016100011

Funding Source: 100% Fund 210 – Sewer Replacement

Work Order: 161280

Comments: Currently 2 sections, (1) a 600 foot section of 8 inch VCP located approximately 600 feet east on Fulton Road from the intersection with Richland Road, and (2) a 100 foot section of 8 inch DIP under North County Transit District’s (NCTD) railroad tracks located 550 feet east of the intersection of the tracks with Woodland Parkway are in need of rehabilitation and/or replacement to restore pipe integrity. Due to extensive longitudinal cracking, a portion of the pipeline on Fulton Road will need to be replaced, however a majority can be rehabilitated using a Cured in Place Pipe (CIPP). Due to the location of the pipeline across the NCTD railroad, rehabilitation of the line will also use the CIPP method. These pipe sections have become compromised either due to age, material type, or ground settlement requiring rehabilitation/replacement. Significant costs will be accrued upon line failure if the sections of pipe are not rehabilitated or replaced.

Operations Impact: Restored or replace structural integrity and increased service life of sewer line sections.

Project Spending Plan

Project Phase	Previous Spending	FY 17/18	FY 18/19	FY 19/20	FY 20/21	FY 21/22 & Thereafter	Total
Planning	\$5,000						\$5,000
Design	\$25,000	\$15,000					\$40,000
Construction		\$98,000					\$98,000
Total	\$30,000	\$113,000	\$0	\$0	\$0	\$0	\$143,000

FY 2017/18 Budget Request - \$0

Estimated Project Timeline

Project Approval	Planning		Design		Construction		Completion
	Begin	End	Begin	End	Begin	End	
Jul 2016	Jul 2016	Mar 2017	Apr 2017	Jul 2017	Aug 2017	Dec 2018	Dec 2018

Capital Improvement Program Palos Vista Pump Station - Motor Replacement

Description: Replace the motors on all four pumps at Palos Vista Pump Station.



Project Manager: Robert Salazar

Department: Mechanical/Electrical

Project: 2016100008

Funding Source: 100% Fund 110 – Water Replacement

Comments: The existing pump motors have been in service for over 20 years. They are no longer efficient and should be upgraded to the new premium efficiency motors. The new motors will operate more efficiently and save on energy costs.

Operations Impact: Improved reliability and efficiency at Palos Vista Pump Station. Potential savings in electrical costs. Normal maintenance.

Project Spending Plan

Project Phase	Previous Spending	FY 17/18	FY 18/19	FY 19/20	FY 20/21	FY 21/22 & Thereafter	Total
Planning							
Design							
Construction	\$54,000	\$32,000	\$32,000				\$118,000
Total	\$54,000	\$32,000	\$32,000	\$0	\$0	\$0	\$118,000

FY 2017/18 Budget Request - \$0

Estimated Project Timeline

Project Approval	Planning		Design		Construction		Completion
	Begin	End	Begin	End	Begin	End	
Jul 2015					Jul 2015	Jun 2019	Jun 2019

Capital Improvement Program Building B Laminate Floor Replacement

Description: The flooring in B building is peeling up. To prevent trip hazards this project will thoroughly seal the concrete below and lay the new laminate.



Project Manager: Dennis Bowman

Department: Warehouse/Purchasing

Project: 2017100009

Funding Source: 51% Fund 110 – Water Replacement
49% Fund 210 - Sewer Replacement

Comments: Remove old flooring, seal concrete, and install new flooring.

Operations Impact: None

Project Spending Plan

Project Phase	Previous Spending	FY 17/18	FY 18/19	FY 19/20	FY 20/21	FY 21/22 & Thereafter	Total
Planning							
Design							
Construction		\$40,000					\$40,000
Total	\$0	\$40,000	\$0	\$0	\$0	\$0	\$40,000

FY 2017/18 Budget Request - \$0

Estimated Project Timeline

Project Approval	Planning		Design		Construction		Completion
	Begin	End	Begin	End	Begin	End	
Jul 2016							Jun 2018

Capital Improvement Program Lake San Marcos Lift Station - Motor Replacement

Description: Replace outdated motors with new efficient motors.



Project Manager: Robert Salazar

Department: Mechanical/Electrical

Project: 2017100011

Funding Source: 100% Fund 210 – Sewer Replacement

Comments: Motors at this site were installed almost nineteen years ago and have exceeded their useful life. Although they have been repaired or reconditioned over the years, it is cost effective at this time to purchase new Premium Efficiency motors to save on energy costs and increase reliability of operation.

Operations Impact: Routine maintenance.

Project Spending Plan

Project Phase	Previous Spending	FY 17/18	FY 18/19	FY 19/20	FY 20/21	FY 21/22 & Thereafter	Total
Planning							
Design							
Construction	\$18,000	\$18,000					\$36,000
Total	\$18,000	\$18,000	\$0	\$0	\$0	\$0	\$36,000

FY 2017/18 Budget Request - \$0

Estimated Project Timeline

Project Approval	Planning		Design		Construction		Completion
	Begin	End	Begin	End	Begin	End	

Capital Improvement Program HVAC Pump and Motor Replacement

Description: There are two pumps that supply the cold water to the building for adequate temperature and proper operation. One motor had to be replaced in an emergency and the other is starting to fail.

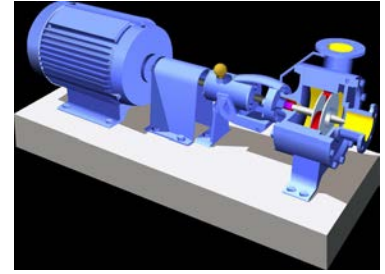

Project Manager: Dennis Bowman

Department: Warehouse/Purchasing

Project: 2017100016

Funding Source: 51% Fund 110 – Water Replacement
49% Fund 210 - Sewer Replacement

Comments: Remove old pump and motor skid. Drain the system and install new unit to maintain proper operation of the HVAC system.

Operations Impact: None

Project Spending Plan

Project Phase	Previous Spending	FY 17/18	FY 18/19	FY 19/20	FY 20/21	FY 21/22 & Thereafter	Total
Planning							
Design							
Construction		\$20,000					\$20,000
Total	\$0	\$20,000	\$0	\$0	\$0	\$0	\$20,000

FY 2017/18 Budget Request - \$0

Estimated Project Timeline

Project Approval	Planning		Design		Construction		Completion
	Begin	End	Begin	End	Begin	End	
Jul 2016							Jun 2018

Capital Improvement Program Encina Wastewater Authority Five Year Plan

Description: The District is a member agency of the Encina Wastewater Authority (EWA). The District shares in the cost of planned asset replacements and capital acquisitions.



Project Manager: Tom Scaglione

Department: General Manager

Project: 2018100001

Funding Source: 77% Fund 210 – Sewer Replacement
23% Fund 220 – Sewer Capacity

Comments: These miscellaneous capital projects are budgeted each year

Operations Impact: No significant increase in costs or changes in efficiencies are anticipated from this project..

Project Spending Plan

Project Phase	Previous Spending	FY 17/18	FY 18/19	FY 19/20	FY 20/21	FY 21/22 & Thereafter	Total
Planning							
Design							
Construction		\$3,236,000	\$4,703,000	\$4,796,000	\$3,400,000	\$3,110,000	\$19,245,000
Total	\$0	\$3,236,000	\$4,703,000	\$4,796,000	\$3,400,000	\$3,110,000	\$19,245,000

FY 2017/18 Budget Request - \$19,245,000

Estimated Project Timeline

Project Approval	Planning		Design		Construction		Completion
	Begin	End	Begin	End	Begin	End	
Jul 2009						Jun 2021	

Capital Improvement Program Elser Lane Water Line Improvements

Description: Project will insure reliability and improve water quality for residents along Elser Lane by transferring water services to a new 6" distribution main instead of the existing 18" transmission main.



Project Manager: Jason Hubbard

Department: Engineering

Project: 2018100002

Funding Source: 100% Fund 110 – Water Replacement

Comments: An existing 18" steel (CML&C) transmission main between Rees Road and Rock Springs Road was installed in 1956. This line runs between homes, underneath structures, and in backyards where access is limited. Should repairs need to be made to this line, there is a greater chance of damage to property owners. This line also serves approximately 21 residential meters. This project will bring this area into District standards by extending new 6" distribution water lines on Elser Lane to service residents with new water meters. New connections to existing water lines in McLees Court will create a loop in the water supply system, insuring reliability of service and improving water quality. This project also offsets future costs to relocate the water main under the Rees Road Water Line Project.

Operations Impact: Improve reliability and water quality. Routine maintenance.

Project Spending Plan

Project Phase	Previous Spending	FY 17/18	FY 18/19	FY 19/20	FY 20/21	FY 21/22 & Thereafter	Total
Planning		\$15,000	\$15,000	\$60,000			\$90,000
Design			\$50,000	\$100,000			\$150,000
Construction				\$250,000	\$1,275,000		\$1,525,000
Total	\$0	\$15,000	\$65,000	\$410,000	\$1,275,000	\$0	\$1,765,000

FY 2017/18 Budget Request - \$1,765,000

Estimated Project Timeline

Project Approval	Planning		Design		Construction		Completion
	Begin	End	Begin	End	Begin	End	
Jul 2017	May 2018	Sep 2018	Oct 2018	Oct 2019	Nov 2018	Jun 2019	Jun 2019

Capital Improvement Program Schoolhouse Tank Refurbishment

Description: Schoolhouse Tank requires interior refurbishment.



Project Manager: Jason Hubbard

Department: Engineering

Project: 2018100003

Funding Source: 100% Fund 110 – Water Replacement

Comments: The existing interior lining of the 2.4 MG tank has deteriorated and requires full refurbishment. This project will remove the existing lining and install a new interior lining. Repairs to the ceiling rafters and equipment upgrades may also be necessary.

Operations Impact: Prevent further delamination of the existing lining. Routine maintenance

Project Spending Plan

Project Phase	Previous Spending	FY 17/18	FY 18/19	FY 19/20	FY 20/21	FY 21/22 & Thereafter	Total
Planning		\$5,000					\$5,000
Design		\$40,000					\$40,000
Construction		\$630,000					\$630,000
Total	\$0	\$675,000	\$0	\$0	\$0	\$0	\$675,000

FY 2017/18 Budget Request - \$675,000

Estimated Project Timeline

Project Approval	Planning		Design		Construction		Completion
	Begin	End	Begin	End	Begin	End	
Jun 2017	Jul 2017	Jul 2017	Aug 2017	Oct 2017	Jan 2018	May 2018	May 2018

Capital Improvement Program Las Posas 10-inch Water Main Replacement

Description: Replace 495 feet of existing 10" ACP pipe along Las Posas Road from Linda Vista Drive to Stone Drive.



Project Manager: Jason Hubbard

Department: Engineering

Project: 2018100004

Funding Source: 100% Fund 110 – Water Replacement

Comments: The 10" ACP water main along Las Posas Road from Linda Vista Drive to Stone Drive is aging and in need of replacement. It has experienced a break in recent years and control valves associated with this water main are non-operational. The replacement will involve crossing underneath an existing double reinforced box culvert with a new steel casing.

Operations Impact: Prevent future breaks. Routine maintenance.

Project Spending Plan

Project Phase	Previous Spending	FY 17/18	FY 18/19	FY 19/20	FY 20/21	FY 21/22 & Thereafter	Total
Planning		\$15,000					\$15,000
Design			\$25,000				\$25,000
Construction			\$540,000				\$540,000
Total	\$0	\$15,000	\$565,000	\$0	\$0	\$0	\$580,000

FY 2017/18 Budget Request - \$580,000

Estimated Project Timeline

Project Approval	Planning		Design		Construction		Completion
	Begin	End	Begin	End	Begin	End	
Jun 2017	Jan 2018	Jun 2018	Jul 2018	Dec 2018	Jan 2019	Mar 2019	Mar 2019

Capital Improvement Program Stargaze Court Water Line Replacement

Description: Replace approximately 729 LF of existing 8" water line in Stargaze Court. The pipeline has failed numerous occasions over the past few years due to excessive corrosion and more failures are anticipated due to highly corrosive subsurface conditions.



Project Manager: Jason Hubbard

Department: Engineering

Project: 2018100005

Funding Source: 100% Fund 110 – Water Replacement

Comments: This project will prevent the existing pipeline from further failure due to corrosion by replacing the ductile iron pipe with a non-corrosive pipe material.

Operations Impact: The existing waterline is corroding and subject to replacement. Operations and maintenance repair costs will be minimized at this location.

Project Spending Plan

Project Phase	Previous Spending	FY 17/18	FY 18/19	FY 19/20	FY 20/21	FY 21/22	Total
Planning		\$20,000					\$20,000
Design		\$60,000					\$60,000
Construction		\$320,000					\$320,000
Total	\$0	\$400,000	\$0	\$0	\$0	\$0	\$400,000

FY 2017/18 Budget Request - \$400,000

Estimated Project Timeline

Project Approval	Planning		Design		Construction		Completion
	Begin	End	Begin	End	Begin	End	
Jun 2017	Jul 2017	Aug 2017	Jul 2017	Sep 2017	Nov 2017	Feb 2018	Feb 2018

**Capital Improvement Program
Palos Vista Pump Station – Generator**

Description: Install new permanent generator with manual transfer switch.



Project Manager: Robert Salazar

Department: Mechanical/Electrical

Project: 2018100006

Funding Source: 100% Fund 110 – Water Replacement

Comments: Palos Vista Pump Station has no permanent generator for emergency power. To insure reliability to this facility, an APCD/CARB compliant generator will need to be installed at the station. Improvements will also include an manual transfer switch, enclosure, concrete pad, and conduit.

Operations Impact: Provide reliability to the pump station in the event of a power failure. Routine maintenance.

Project Spending Plan

Project Phase	Previous Spending	FY 17/18	FY 19/20	FY 20/21	FY 21/22	Thereafter	Total
Planning		\$3,000					\$3,000
Design		\$27,000					\$27,000
Construction		\$295,000					\$295,000
Total	\$0	\$325,000	\$0	\$0	\$0	\$0	\$325,000

FY 2017/18 Budget Request - \$325,000

Estimated Project Timeline

Project Approval	Planning		Design		Construction		Completion
	Begin	End	Begin	End	Begin	End	
Jul 2016	Jul 2017	Aug 2017	Sep 2017	Jan 2018	Feb 2018	May 2018	May 2018

Capital Improvement Program Solar Panel Invertor Replacement

Description: Replace two existing invertors with new Solectria invertors to insure proper operation and solar efficiency.



Project Manager: Dennis Bowman

Department: Warehouse/Purchasing

Project: 2018100007

Funding Source: 51% Fund 110 – Water Replacement
49% Fund 210 - Sewer Replacement

Comments: Our solar panel invertors are very old and the company that made them went out of business. It is very difficult to find the necessary materials to make repairs which costs the district money when they are down. We would like to replace them with updated invertors to insure proper operation and energy efficiency.

Operations Impact: Engineering impact for larger contract preparation Warehouse impact when quotes are gather and meetings with contractors.

Project Spending Plan

Project Phase	Previous Spending	FY 17/18	FY 18/19	FY 19/20	FY 20/21	FY 21/22 & Thereafter	Total
Planning		\$10,000					\$10,000
Design		\$20,000					\$20,000
Construction		\$265,000					\$265,000
Total	\$0	\$295,000	\$0	\$0	\$0	\$0	\$295,000

FY 2017/18 Budget Request - \$295,000

Estimated Project Timeline

Project Approval	Planning		Design		Construction		Completion
	Begin	End	Begin	End	Begin	End	
Jul 2017	Jul 2017	Jun 2018	Jul 2017	Jun 2018	Jul 2017	Jun 2018	Jun 2018

Capital Improvement Program Laurels Sewer Lining

Description: Clean and repair of approximately 1,130 feet of 8" sewer lines in Acacia Street, Sequoia Street and adjacent District easements.



Project Manager: Eric Garcia

Department: Engineering

Project: 2018100008

Funding Source: 100% Fund 210 – Sewer Replacement

Comments: The 8" sewer line in Acacia Street, Sequoia Street and in adjacent District easements are in need of cleaning and repairs. Cleaning, CIPP liner, and point repairs are necessary.

Operations Impact:

Project Spending Plan

Project Phase	Previous Spending	FY 17/18	FY 18/19	FY 19/20	FY 20/21	FY 21/22 & Thereafter	Total
Planning		\$5,000					\$5,000
Design		\$15,000					\$15,000
Construction		\$190,000					\$190,000
Total	\$0	\$210,000	\$0	\$0	\$0	\$0	\$210,000

FY 2017/18 Budget Request - \$210,000

Estimated Project Timeline

Project Approval	Planning		Design		Construction		Completion
	Begin	End	Begin	End	Begin	End	
Jun 2017	Jul 2017	Sep 2017	Oct 2017	Feb 2018	Mar 2018	May 2018	May 2018

**Capital Improvement Program
MRF - Replace the Influent Pumps & Motors**

Description: Replacement of the three influent dry-pit submersible pump & motor units with vertical, modular type pump & motor units.



Project Manager: Robert Salazar

Department: Mechanical/Electrical

Project: 2018100009

Funding Source: 100% Fund 210 – Sewer Replacement

Comments: The current dry-pit submersible pump units have to be delivered to a facility that specializes in the repair of sealed pump units. A modular vertical type pump & motor unit can be disassembled, serviced and repaired by District maintenance staff. This reduces repair costs and allows for less down time of the equipment.

Operations Impact: Reduced repair costs and down time. Routine maintenance.

Project Spending Plan

Project Phase	Previous Spending	FY 17/18	FY 18/19	FY 19/20	FY 20/21	FY 21/22 & Thereafter	Total
Planning							
Design							
Construction		\$65,000	\$65,000	\$65,000			\$195,000
Total	\$0	\$65,000	\$65,000	\$65,000	\$0	\$0	\$195,000

FY 2017/18 Budget Request - \$195,000

Estimated Project Timeline

Project Approval	Planning		Design		Construction		Completion
	Begin	End	Begin	End	Begin	End	
Jul 2017							Jun 2020

Capital Improvement Program Nursery Valve Relocation

Description: Relocate the 16" and 18" control valves for the RSF-MRF Conveyance and Emergency Bypass sewer line out of Rancho Santa Fe Road.



Project Manager: Jason Hubbard

Department: Engineering

Project: 2018100010

Funding Source: 100% Fund 210 – Sewer Replacement

Comments: Control valves in Rancho Santa Fe Road, south of Via Cancion, located at the junction between the 18" RSF-MRF Conveyance sewer pipeline and the 16" Emergency Bypass sewer pipeline require full lane shutdown of southbound traffic on Rancho Santa Fe Road. Additionally, the 18" gate valve is no longer functioning. Project will relocate the 18" gate valve to the southside of Redwing Street and the 16" gate valve to the District's easement off Brighton Glen Road. Double sweep cleanouts will be installed upstream of the 16" gate valve to assist in routine cleaning and maintenance.

Operations Impact: Reduce traffic control costs and improve safety. Routine maintenance.

Project Spending Plan

Project Phase	Previous Spending	FY 17/18	FY 18/19	FY 19/20	FY 20/21	FY 21/22	Total
Planning							
Design		\$15,000					\$15,000
Construction		\$175,000					\$175,000
Total	\$0	\$190,000	\$0	\$0	\$0	\$0	\$190,000

FY 2017/18 Budget Request - \$190,000

Estimated Project Timeline

Project Approval	Planning		Design		Construction		Completion
	Begin	End	Begin	End	Begin	End	
Jul 2017			Jul 2017	Sep 2017	Oct 2017	Dec 2017	Dec 2017

Capital Improvement Program MRF - Tertiary Influent Chamber Repairs

Description: The Tertiary Influent Chamber at the Meadowlark Water Reclamation Facility (MRF) requires repairs to the protective coating.

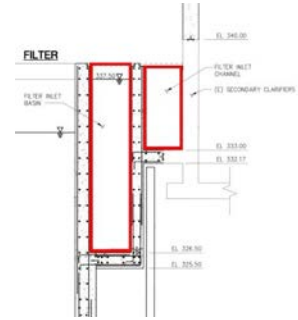

Project Manager: Dawn McDougle

Department: Meadowlark Reclamation Facility

Project: 2018100011

Funding Source: 100% Fund 250 - Reclaimed

Comments: The existing high solids epoxy, lining the MRF Tertiary Influent Chamber, is failing and in need of repair. The chamber transitions Secondary wastewater effluent to the Tertiary Filter basins. Using bypass methods, the chamber's protective lining will need to be repaired, including any support brackets and piping, during the low flow season.

Operations Impact: Repairs to the coating will maintain the integrity of the concrete structure.

Project Spending Plan

Project Phase	Previous Spending	FY 17/18	FY 18/19	FY 19/20	FY 20/21	FY 21/22 & Thereafter	Total
Planning							
Design							
Construction		\$115,000					\$115,000
Total	\$0	\$115,000	\$0	\$0	\$0	\$0	\$115,000

FY 2017/18 Budget Request - \$115,000

Estimated Project Timeline

Project Approval	Planning		Design		Construction		Completion
	Begin	End	Begin	End	Begin	End	
Jul 2017	Aug 2017	Aug 2017	Sep 2017	Nov 2017	Dec 2017	Jan 2018	Jan 2018

Capital Improvement Program Sewer Replacement and I&I Repairs

Description: During the course of the year, unexpected damage and emergency repairs are needed. This budget item sets aside money to perform necessary repairs.



Project Manager: Eric Garcia

Department: Systems Collection

Project: 2018100012

Funding Source: 100% Fund 210 – Sewer Replacement

Comments: These funds will only be used after review and approval by the District Engineer and the Operations and Maintenance Manager.

Operations Impact: None.

Project Spending Plan

Project Phase	Previous Spending	FY 17/18	FY 18/19	FY 19/20	FY 20/21	FY 21/22 & Thereafter	Total
Planning							
Design							
Construction		\$100,000					\$100,000
Total	\$0	\$100,000	\$0	\$0	\$0	\$0	\$100,000

FY 2017/18 Budget Request - \$100,000

Estimated Project Timeline

Project Approval	Planning		Design		Construction		Completion
	Begin	End	Begin	End	Begin	End	
Jul 2017							Jun 2018

Capital Improvement Program South Lake - Facility Upgrades

Description: Upgrade the facilities at South Lake to comply with state regulations.



Project Manager: Kevin Antcil

Department: Construction

Project: 2018100013

Funding Source: 100% Fund 110 – Water Replacement

Comments: South Lake has not been used for potable water storage since 1984, but the pipeline into the lake is still connected to the distribution system. We have been unable to correct this because the sluice gate on the dam has not been operational. The sluice gate was recently replaced and we can now disconnect the lake from the potable distribution system. A section of pipe will be removed just downstream from the dam with new valves and blind flanges installed in case a future connection is desired. A new drain valve will be installed for the lake and the leak pumping system will be relocated above ground. The facility upgrades are necessary to comply with state regulations regarding the operation of South Lake Dam.

Operations Impact: Removal of a potential cross-connection to the distribution system, enhanced operation of the lake, and compliance with state regulations.

Project Spending Plan

Project Phase	Previous Spending	FY 17/18	FY 18/19	FY 19/20	FY 20/21	FY 21/22 & Thereafter	Total
Planning							
Design							
Construction		\$95,000					\$95,000
Total	\$0	\$95,000	\$0	\$0	\$0	\$0	\$95,000

FY 2017/18 Budget Request - \$95,000

Estimated Project Timeline

Project Approval	Planning		Design		Construction		Completion
	Begin	End	Begin	End	Begin	End	
Jul 2017							Jun 2018

Capital Improvement Program Replace Roofs on Equipment Storages

Description: Replace roofs on the car wash, fuel island, and two equipment storages with more durable metal roofing.



Project Manager: Dennis Bowman

Department: Warehouse/Purchasing

Project: 2018100014

Funding Source: 51% Fund 110 – Water Replacement
49% Fund 210 - Sewer Replacement

Comments: The fiberglass corrugated roofing is 22 years old and needs to be replaced because it is a safety concern.

Operations Impact: Warehouse and Administrative impact for quoting and contract write up/organization.

Project Spending Plan

Project Phase	Previous Spending	FY 17/18	FY 18/19	FY 19/20	FY 20/21	FY 21/22 & Thereafter	Total
Planning		\$5,000					\$5,000
Design		\$2,000					\$2,000
Construction		\$70,000					\$70,000
Total	\$0	\$77,000	\$0	\$0	\$0	\$0	\$77,000

FY 2017/18 Budget Request - \$77,000

Estimated Project Timeline

Project Approval	Planning		Design		Construction		Completion
	Begin	End	Begin	End	Begin	End	
Jul 2017	Jul 2017	Jun 2018	Jul 2017	Jun 2018	Jul 2017	Jun 2018	Jun 2018

Capital Improvement Program Coronado Hills Chlorine Injection System

Description: Installation of a calcium hypochlorite injection system at Coronado Hills Tank for residual maintenance and control of nitrification.



Project Manager: Shawn Askine

Department: Water Operations

Project: 2018100015

Funding Source: 100% Fund 110 – Water Replacement

Comments: Coronado Hills Tank is one of our reservoirs that consistently experiences problems with water quality due to its large size and low demand conditions. Water System Operators are required to add additional chlorine to this reservoir on a weekly basis for at least nine months of the year. This requires significant staff time and addition of chlorine in an inefficient process. The chlorine injection equipment will allow operators to load the equipment with chlorine tablets and then use the SCADA computer control systems to treat the reservoir during the pumping cycle. This will allow for an improved mixing of the chlorine in the reservoir and reduce staff time. An online chlorine analyzer will also be installed at this location to monitor the water quality and transmit the data into our Water Operations control room.

Operations Impact: Improved water quality within the reservoir and reduced staff time.

Project Spending Plan

Project Phase	Previous Spending	FY 17/18	FY 18/19	FY 19/20	FY 20/21	FY 21/22 & Thereafter	Total
Planning							
Design							
Construction		\$65,000					\$65,000
Total	\$0	\$65,000	\$0	\$0	\$0	\$0	\$65,000

FY 2017/18 Budget Request - \$65,000

Estimated Project Timeline

Project Approval	Planning		Design		Construction		Completion
	Begin	End	Begin	End	Begin	End	
Jul 2017							Jun 2018

Capital Improvement Program Building A Kitchens

Description: Remove and replace old counters with higher grade materials and replace the floor with industrial grade laminate.

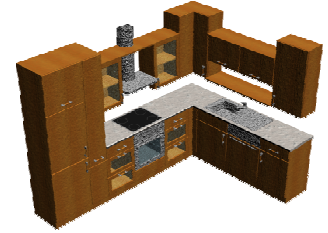

Project Manager: Dennis Bowman

Department: Warehouse/Purchasing

Project: 2018100016

Funding Source: 51% Fund 110 – Water Replacement
49% Fund 210 - Sewer Replacement

Comments: The Building A kitchen and kitchenettes are roughly 20 years old and experience daily use.

Operations Impact: None

Project Spending Plan

Project Phase	Previous Spending	FY 17/18	FY 18/19	FY 19/20	FY 20/21	FY 21/22 & Thereafter	Total
Planning							
Design							
Construction		\$65,000					\$65,000
Total	\$0	\$65,000	\$0	\$0	\$0	\$0	\$65,000

FY 2017/18 Budget Request - \$65,000

Estimated Project Timeline

Project Approval	Planning		Design		Construction		Completion
	Begin	End	Begin	End	Begin	End	
Jul 2017							Jun 2018

Capital Improvement Program Refurbish Pumps at North Twin Oaks Pump Station

Description: Refurbish three 4-stage vertical turbine pumps and motors.



Project Manager: Robert Salazar

Department: Mechanical/Electrical

Project: 2018100017

Funding Source: 100% Fund 110 – Water Replacement

Comments: It is industry standard to inspect and refurbish vertical turbine pumps every 7 to 10 years. These pumps have been in service for approximately 10 years. A refurbishment of the pumps and motors will extend the life of the equipment and maintain peak operating efficiency.

Operations Impact: Routine maintenance.

Project Spending Plan

Project Phase	Previous Spending	FY 17/18	FY 18/19	FY 19/20	FY 20/21	FY 21/22 & Thereafter	Total
Planning							
Design							
Construction		\$63,000					\$63,000
Total	\$0	\$63,000	\$0	\$0	\$0	\$0	\$63,000

FY 2017/18 Budget Request - \$63,000

Estimated Project Timeline

Project Approval	Planning		Design		Construction		Completion
	Begin	End	Begin	End	Begin	End	
Jul 2017							Jun 2018

Capital Improvement Program Wulff Pump Station Pumps & Motors

Description: Remove and refurbish all three 5-stage vertical turbine pumps and motors.



Project Manager: Robert Salazar

Department: Mechanical/Electrical

Project: 2018100018

Funding Source: 100% Fund 110 – Water Replacement

Comments: It is industry standard to inspect and refurbish vertical turbine pumps every 7 to 10 years. These pumps have been in service for approximately 8 years. A refurbishment of the pumps and motors will extend the life of the equipment and maintain peak operating efficiency.

Operations Impact: Improved efficiency. Routine maintenance.

Project Spending Plan

Project Phase	Previous Spending	FY 17/18	FY 18/19	FY 19/20	FY 20/21	FY 21/22 & Thereafter	Total
Planning							
Design							
Construction		\$60,000					\$60,000
Total	\$0	\$60,000	\$0	\$0	\$0	\$0	\$60,000

FY 2017/18 Budget Request - \$60,000

Estimated Project Timeline

Project Approval	Planning		Design		Construction		Completion
	Begin	End	Begin	End	Begin	End	
Jul 2017							Jun 2018

Capital Improvement Program South Lake Pump Station Valves

Description: Replace the check valves and plug valves on pump #1 and #2.



Project Manager: Robert Salazar

Department: Mechanical/Electrical

Project: 2018100019

Funding Source: 100% Fund 110 – Water Replacement

Comments: The existing check valves are 35 years old and need replacing. The plug valves are the same age and no longer operate in isolating the pumps when maintenance and service is required.

Operations Impact: Routine maintenance.

Project Spending Plan

Project Phase	Previous Spending	FY 17/18	FY 18/19	FY 19/20	FY 20/21	FY 21/22 & Thereafter	Total
Planning							
Design							
Construction		\$45,000					\$45,000
Total	\$0	\$45,000	\$0	\$0	\$0	\$0	\$45,000

FY 2017/18 Budget Request - \$45,000

Estimated Project Timeline

Project Approval	Planning		Design		Construction		Completion
	Begin	End	Begin	End	Begin	End	
Jul 2017							Jun 2018

Capital Improvement Program Solar Panels at Poinsettia Odor Control Injection

Description: Install solar panels at Poinsettia odor control injection station.



Project Manager: Eric Garcia

Department: Systems Collection

Project: 2018100020

Funding Source: 100% Fund 220 – Sewer Capacity

Comments: The power supplying the station was intended to be temporary 13 years ago while testing the site’s effectiveness. A cost effective permanent power source needs to be installed. Connecting to the power utility would be extremely expensive. Installing solar panels severs the District’s dependency on the City of Carlsbad’s lift station as a power source.

Operations Impact: Routine maintenance.

Project Spending Plan

Project Phase	Previous Spending	FY 17/18	FY 18/19	FY 19/20	FY 20/21	FY 21/22 & Thereafter	Total
Planning							
Design							
Construction		\$35,000					\$35,000
Total	\$0	\$35,000	\$0	\$0	\$0	\$0	\$35,000

FY 2017/18 Budget Request - \$35,000

Estimated Project Timeline

Project Approval	Planning		Design		Construction		Completion
	Begin	End	Begin	End	Begin	End	
Jul 2017							Jun 2018

Capital Improvement Program Admin Emergency Generator - Auto Transfer Switch

Description: Replace auto transfer switch that facilitates emergency power from the standby generator to dedicated emergency circuits within the Administrative facilities/buildings during planned and unplanned power outages.

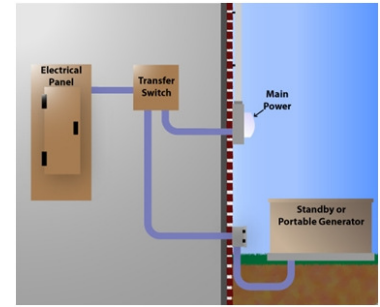

Project Manager: Robert Salazar

Department: Mechanical/Electrical

Project: 2018100021

Funding Source: 50% Fund 110 – Water Replacement
50% Fund 210 – Sewer Replacement

Comments: The existing auto transfer switch is outdated and no longer supported by the manufacturer. The reliability of the switch is in question as electronic components have failed recently. A new auto transfer switch will ensure the reliability of having emergency power available when required.

Operations Impact: Routine maintenance.

Project Spending Plan

Project Phase	Previous Spending	FY 17/18	FY 18/19	FY 19/20	FY 20/21	FY 21/22 & Thereafter	Total
Planning							
Design							
Construction		\$30,000					\$30,000
Total	\$0	\$30,000	\$0	\$0	\$0	\$0	\$30,000

FY 2017/18 Budget Request - \$30,000

Estimated Project Timeline

Project Approval	Planning		Design		Construction		Completion
	Begin	End	Begin	End	Begin	End	
Jul 2017							Jun 2018

Capital Improvement Program Gates for Twin Oaks Reservoir Access Road

Description: Install solar powered automatic gates on the Twin Oaks Reservoir access road.



Project Manager: Ed Pedrazzi

Department: Operations and Maintenance

Project: 2018100022

Funding Source: 100% Fund 120 – Water Capacity

Comments: The Twin Oaks Reservoir access road currently has a large, pole type gate at each end that is designed for occasional use. District staff and vendors routinely use El Paso Alto Road to access the Twin Oaks Reservoir facility. It was recently discovered that El Paso Alto is not a county owned road and is a private road owned by the surrounding nursery. The new gates will allow staff easy access to the District facilities and keep them and our vendors off of the private road. The gate motors and controls will be solar powered which will save the cost of running power to the two gates. The gates will also have a strobe sensor which will provide the fire department emergency access to our facility.

Operations Impact: Routine maintenance.

Project Spending Plan

Project Phase	Previous Spending	FY 17/18	FY 18/19	FY 19/20	FY 20/21	FY 21/22 & Thereafter	Total
Planning							
Design							
Construction		\$25,000					\$25,000
Total	\$0	\$25,000	\$0	\$0	\$0	\$0	\$25,000

FY 2017/18 Budget Request - \$25,000

Estimated Project Timeline

Project Approval	Planning		Design		Construction		Completion
	Begin	End	Begin	End	Begin	End	
Jul 2017							Jun 2018

Capital Improvement Program Palomar Tank - Valve Replacement

Description: Replacement of a 16” gate valve at Palomar Tank.



Project Manager: Shawn Askine

Department: Water Operations

Project: 2018100023

Funding Source: 100% Fund 110 – Water Replacement

Comments: The 16” gate valve used to isolate the tank does not operate. We are repairing the asphalt at this site and need to replace the valve before that project begins.

Operations Impact: Ability to isolate the tank. Routine maintenance.

Project Spending Plan

Project Phase	Previous Spending	FY 17/18	FY 18/19	FY 19/20	FY 20/21	FY 21/22 & Thereafter	Total
Planning							
Design							
Construction		\$25,000					\$25,000
Total	\$0	\$25,000	\$0	\$0	\$0	\$0	\$25,000

FY 2017/18 Budget Request - \$25,000

Estimated Project Timeline

Project Approval	Planning		Design		Construction		Completion
	Begin	End	Begin	End	Begin	End	
Jul 2017							Jun 2018

Capital Improvement Program Mountain Belle Tank - Valve Replacement

Description: Replacement of two 12” gate valves at Mountain Belle Tank.



Project Manager: Shawn Askine

Department: Water Operations

Project: 2018100024

Funding Source: 100% Fund 110 – Water Replacement

Comments: The two 12” butterfly valves used to isolate the tank do not operate. We are repairing the asphalt at this site and need to replace the valves before that project begins. We will replace the two butterfly valves with gate valves which provide better isolation.

Operations Impact: Ability to isolate the tank. Routine maintenance.

Project Spending Plan

Project Phase	Previous Spending	FY 17/18	FY 18/19	FY 19/20	FY 20/21	FY 21/22 & Thereafter	Total
Planning							
Design							
Construction		\$20,000					\$20,000
Total	\$0	\$20,000	\$0	\$0	\$0	\$0	\$20,000

FY 2017/18 Budget Request - \$20,000

Estimated Project Timeline

Project Approval	Planning		Design		Construction		Completion
	Begin	End	Begin	End	Begin	End	
Jul 2017							Jun 2018

**Capital Improvement Program
Office Wall for Senior Construction Workers**

Description: Build a wall for the Senior Construction Worker office.



Project Manager: Ed Pedrazzi

Department: Operations and Maintenance

Project: 2018100025

Funding Source: 50% Fund 110 – Water Replacement
50% Fund 210 – Sewer Replacement

Comments: The current office for the two Senior Construction Workers does not have a wall that separates them from the staff traveling through the Operations building. This is very distracting and disruptive when they are trying to complete their daily computer work. This project will provide a wall for the office and create a hallway for other staff to use when accessing the Construction crew room.

Operations Impact: Improved work environment for Senior Construction Workers.

Project Spending Plan

Project Phase	Previous Spending	FY 17/18	FY 18/19	FY 19/20	FY 20/21	FY 21/22 & Thereafter	Total
Planning							
Design							
Construction		\$17,000					\$17,000
Total	\$0	\$17,000	\$0	\$0	\$0	\$0	\$17,000

FY 2017/18 Budget Request - \$17,000

Estimated Project Timeline

Project Approval	Planning		Design		Construction		Completion
	Begin	End	Begin	End	Begin	End	
Jul 2017							Jun 2018

Capital Improvement Program Office Wall for Application Specialist Staff

Description: Build a wall for the Application Specialist staff



Project Manager: Karla Fisher

Department: Information Technology

Project: 2018100026

Funding Source: 50% Fund 110 – Water Replacement
50% Fund 210 – Sewer Replacement

Comments: The current work area for the two Application Specialists does not have a wall that separates them from the main hallway. These positions work with confidential district, employee and customer data as part of their role supporting the business application infrastructure.

Operations Impact: Application Specialist staff work with confidential district, employee and customer data as part of their role supporting the district's business application software enterprise.

Project Spending Plan

Project Phase	Previous Spending	FY 17/18	FY 18/19	FY 19/20	FY 20/21	FY 21/22 & Thereafter	Total
Planning							
Design							
Construction		\$17,000					\$17,000
Total	\$0	\$17,000	\$0	\$0	\$0	\$0	\$17,000

FY 2017/18 Budget Request - \$17,000

Estimated Project Timeline

Project Approval	Planning		Design		Construction		Completion
	Begin	End	Begin	End	Begin	End	
Jul 2017							Jun 2018

Capital Improvement Program Future Projects

Description: This amount is set-aside to cover projects planned within the next five years with a start date later than the current fiscal year..



Project Manager: Jason Hubbard

Department: Engineering

Project: TBA

Funding Source: See Below

<u>Project:</u>	<u>Amount:</u>	<u>Source:</u>
El Norte Parkway Water Line Extension	10,530,000	100% Fund 110 – Water Replacement
Rees Road 18" Water Line Relocation	5,780,000	100% Fund 110 – Water Replacement
Tres-Amigos Water Line Replacement Phase 1	2,395,000	100% Fund 110 – Water Replacement
Camino de Amigos Sewer Replacement	1,363,000	45% Fund 210 – Sewer Replacement, 55% Fund 220 – Sewer Capacity
Sage Canyon Tank Refurbishment	890,000	100% Fund 110 – Water Replacement
Deer Springs Pump Station Improvements	555,000	100% Fund 120 – Water Capacity
Deer Springs Tank No.2	520,000	100% Fund 120 – Water Capacity
Coronado Hills Tank Exterior Refurbishment	310,000	100% Fund 110 – Water Replacement
Coggan Pump Station - Generator	285,000	100% Fund 120 – Water Capacity
Richland I Tank Exterior Refurbishment	225,000	100% Fund 110 – Water Replacement
Total	\$22,853,000	

Comments: These projects are part of the District's capital budget beginning after fiscal year 2017-18.

Operations Impact: Normal Maintenance for infrastructure

Project Spending Plan

Project Phase	Previous Spending	FY 17/18	FY 18/19	FY 19/20	FY 20/21	FY 21/22 & Thereafter	Total
Planning			\$460,000	\$5,000	\$58,000	\$460,000	\$983,000
Design			\$220,000	\$170,000	\$100,000	\$1,315,000	\$1,805,000
Construction			\$1,130,000	\$1,015,000	\$1,205,000	\$16,715,000	\$20,065,000
Total	\$0	\$0	\$1,810,000	\$1,190,000	\$1,363,000	\$18,490,000	\$22,853,000

FY 2017/18 Budget Request - \$22,853,000.00

Estimated Project Timeline

Project Approval	Planning		Design		Construction		Completion
	Begin	End	Begin	End	Begin	End	
					Jan 2019	Jun 2026	Jun 2026

VALLECITOS WATER DISTRICT

2017-18 CAPITAL BUDGET - EASEMENTS, VEHICLES & EQUIPMENT SCHEDULE

EASEMENTS						
Requesting				<u>Funding Source:</u>		Total
Dept.	Description	Project #		Water	Sewer	Cost
Development Services:						
Easement		2018100027			\$ 50,000	\$ 50,000
VEHICLES/MOBILE EQUIPMENT						
Existing			New or	<u>Funding Source:</u>		Total
Vehicle #	Description	Project #	Replacement	Water	Sewer	Cost
Construction:						
	Peterbilt 367 10 Wheeler Dump Truck & Construction Bed	2018100028	New	199,000		199,000
217	Ford-F550 Super Duty	2018100029	Replacement	62,000		62,000
Mechanical/Electrical:						
172	Ford-F550 2WD Chassis with Service Body and Crane	2018100030	Replacement	61,700	59,300	121,000
Collections:						
	Water Truck - Model 108SD with ISL Cummins	2018100031	Replacement		101,000	101,000
Meadowlark Facility:						
	Forklift	2018100032	New		36,000	36,000
Water Operations:						
219	Ford F-150 SuperCab XL	2018100033	Replacement	33,000		33,000
Buildings and Grounds						
170	Ford Think Cart	2018100034	Replacement	7,600	7,400	15,000
TOTAL VEHICLES						\$ 567,000
FACILITIES AND EQUIPMENT						
Requesting			New or	<u>Funding Source:</u>		Total
Dept.	Description	Project #	Replacement	Water	Sewer	Cost
Collections:						
	Poly Chemical Tank - 6,500 Gallon for Lift Station 1	2018100035	New		45,000	45,000
252	CCTV Transporter	2018100036	Replacement		26,000	26,000
Water Operations:						
	Tank Cleaning and Disinfection Trailer	2018100037	New	45,000		45,000
Meadowlark Facility:						
	Chemical Mixer	2018100038	New		35,000	\$ 35,000
	Augers Rotating Assemblies (2)	2018100039	Replacement		16,000	16,000
	Turbidity Meters	2018100040	Replacement		18,000	18,000
Construction:						
	NuConcepts Portable Toilet with Hand Wash Station	2018100041	Replacement	8,200	7,800	16,000
TOTAL FACILITIES AND EQUIPMENT						\$ 201,000
VEHICLES & EQUIPMENT TOTAL						\$ 818,000

VALLECITOS WATER DISTRICT

DEBT SERVICE BUDGET FOR THE YEAR ENDING JUNE 30, 2018

	Water		Wastewater		Total
	Replacement	Capacity	Replacement	Capacity	
2005 COP & 2015 Refunding					
Outstanding principal as of July 1, 2017 ⁽¹⁾	\$ -	\$ 24,061,100	\$ -	\$ 23,163,900	\$ 47,225,000
June 23, 2016 Principal Transfer to Trustee	-	(973,150)	-	(936,850)	(1,910,000)
Outstanding principal as of July 1, 2018	<u>\$ -</u>	<u>\$ 23,087,950</u>	<u>\$ -</u>	<u>\$ 22,227,050</u>	<u>\$ 45,315,000</u>
2008 Private Placement ⁽²⁾					
Outstanding principal as of July 1, 2017	\$ -	\$ -	\$ -	\$ 4,600,000	\$ 4,600,000
2016/17 Principal Payments	-	-	-	(400,000)	(400,000)
Outstanding principal as of June 30, 2018	<u>\$ -</u>	<u>\$ -</u>	<u>\$ -</u>	<u>\$ 4,200,000</u>	<u>\$ 4,200,000</u>
2012 Debt ⁽³⁾					
Outstanding principal as of July 1, 2017	\$ -	\$ -	\$ -	\$ 4,434,000	\$ 4,434,000
2016/17 Principal Payments	-	-	-	(702,000)	(702,000)
Outstanding principal as of June 30, 2018	<u>\$ -</u>	<u>\$ -</u>	<u>\$ -</u>	<u>\$ 3,732,000</u>	<u>\$ 3,732,000</u>
2017/18 Debt Service Budget					
2005 COP & 2015 Revenue Refunding principal	\$ -	\$ 973,150	\$ -	\$ 936,850	\$ 1,910,000
2005 COP & 2015 Revenue Refunding interest	-	1,170,320	-	1,126,680	2,297,000
2008 Private Placement - principal	-	-	-	400,000	400,000
2008 Private Placement - interest	-	-	-	49,000	49,000
2012 Debt - principal	-	-	-	702,000	702,000
2012 Debt - interest	-	-	-	81,000	81,000
Total 2017/18 Debt Service Budget	<u>\$ -</u>	<u>\$ 2,143,470</u>	<u>\$ -</u>	<u>\$ 3,295,530</u>	<u>\$ 5,439,000</u>

Projected Debt Service Coverage Ratio ⁽⁴⁾	
	286%
Excluding Capital Facility Fees	218%
Excluding Capital Facility Fees and Property Tax	149%
Days of Operating Expenses in Unrestricted Cash and Investments	329

⁽¹⁾ The 17/18 principal payment on the refunding bonds is due to bondholders on July 1, 2017. The District is obligated to transfer the payment before June 30, 2016, to a restricted account maintained by the Trustee, and, therefore, was deducted from the projected July 1, 2017 balance presented in the Reserve Budget.

⁽²⁾ Cash and corresponding amounts of debt were transferred from replacement funds to restricted capital facility funds to reduce deficit balances.

⁽²⁾ The District and Union Bank of California executed an \$8 million tax-exempt private placement with variable rate interest tied to the LIBOR. The District has the option of changing the LIBOR term. The current term is six months. The current rate is 1.31767%. The proceeds partially restored a deficit balance in the restricted wastewater capacity fund from cash funding construction of the Encina Wastewater Authority Phase V expansion.

⁽³⁾ The District issued bonds on December 21, 2012, to fund the increased capacity portions of San Marcos Interceptor and Linda Vista Sewer projects. The bonds have a 1.98% interest rate over the 10-year term.

⁽⁴⁾ Per the 2005 Certificate of Participation official statement, the District is required to maintain a debt service coverage ratio of 1.15. Debt service coverage ratios are presented above inclusive and exclusive of capital facilities fees to demonstrate the District's ability to cover debt service above the required minimum. Capital facility fees are included in the official statement's definition of "Net Revenues".

This page intentionally left blank

2017-18 LONG-RANGE PLANNING



VALLECITOS WATER DISTRICT

RESERVE BUDGET FOR THE YEAR ENDING JUNE 30, 2018

	110 Water 120		210 Wastewater 220		Total
	Replacement	Capacity	Replacement	Capacity	
Projected July 1, 2017 Balance	\$ 29,729,000	\$ (10,607,000)	\$ 45,163,000	\$ (7,876,000)	\$ 56,409,000
Revenues and Transfers In					
Operating Transfers	1,023,000	-	6,426,000	-	7,449,000
Grant Proceeds	-	-	132,000	206,000	338,000
Capital Facility Fees	-	1,522,000	-	2,149,000	3,671,000
Property Tax	1,169,000	-	928,000	-	2,097,000
RDA pass-through	800,000	-	800,000	-	1,600,000
Investment Earnings	315,000	(122,000)	492,000	(110,000)	575,000
Payment on Land Sale to City	74,000	-	74,000	-	148,000
Available Balance	<u>33,110,000</u>	<u>(9,207,000)</u>	<u>54,015,000</u>	<u>(5,631,000)</u>	<u>72,287,000</u>
Less 17/18 Appropriations and Transfers Out					
Encina Wastewater Authority Five Year Plan	-	-	3,232,000	4,000	3,236,000
Rock Springs Sewer Replacement	-	-	1,188,000	1,452,000	2,640,000
San Marcos Interceptor	-	-	496,000	1,104,000	1,600,000
Land Outfall Clearing & Access Road	-	-	800,000	-	800,000
Schoolhouse Tank Refurbishment	675,000	-	-	-	675,000
Expansion of the Men's Locker Room in Building B	341,700	-	328,300	-	670,000
City of San Marcos Joint Projects	397,000	-	253,000	-	650,000
Encina Wastewater Authority FY 16/17	-	-	650,000	-	650,000
Vehicles	363,000	-	204,000	-	567,000
Stargaze Court Water Line Replacement	400,000	-	-	-	400,000
Montiel Gravity Outfall	-	-	171,000	209,000	380,000
Palos Vista Pump Station – Generator	325,000	-	-	-	325,000
North Vista Pressure Reducing Station Upgrade	305,000	-	-	-	305,000
Solar Panel Invertor Replacement	150,000	-	145,000	-	295,000
Audiovisual Upgrade	127,000	-	123,000	-	250,000
Lift Station 1 Wet Well Room Repairs	-	-	215,000	-	215,000
Laurels Sewer Lining	-	-	210,000	-	210,000
Equipment	53,000	-	148,000	-	201,000
Asset Management Replacement Schedule	100,000	-	100,000	-	200,000
South Vista Pressure Reducing Station Upgrade	195,000	-	-	-	195,000
Nursery Valve Relocation	-	-	190,000	-	190,000
District-wide Valve Replacement Program	175,000	-	-	-	175,000
Via Vera Cruz Tank Hill Stabilization	137,000	-	-	-	137,000
MRF - Tertiary Influent Chamber Repairs	-	-	115,000	-	115,000
Fulton Road and NCTD Sewer Line Rehabilitation	-	-	113,000	-	113,000
Vulnerability Assessment Improvements	57,000	-	54,000	-	111,000
Water and Sewer Master Plan	-	50,000	-	50,000	100,000
Sewer Replacement and I&I Repairs	-	-	100,000	-	100,000
Miscellaneous Projects	635,000	25,000	338,000	132,000	1,130,000
Fund OPEB Trust	1,002,000	-	963,000	-	1,965,000
Debt Service - 2012 Debt	-	-	-	783,000	783,000
Debt Service - 2008 Loan	-	-	-	449,000	449,000
Debt Service - 2015 Refunding	-	2,115,000	-	2,037,000	4,152,000
Less Total Appropriations/Transfers	<u>6,072,700</u>	<u>2,215,000</u>	<u>10,474,300</u>	<u>6,317,000</u>	<u>25,079,000</u>
Projected June 30, 2018 Balance	27,037,300	(11,422,000)	43,540,700	(11,948,000)	\$ 47,208,000
Less Operating Reserves	5,539,100	-	6,518,000	-	12,057,100
Projected replacement reserve/restricted funds	<u>\$ 21,498,200</u>	<u>\$ (11,422,000)</u>	<u>\$ 37,022,700</u>	<u>\$ (11,948,000)</u>	<u>\$ 35,150,900</u>
Adopted replacement reserve floor	<u>\$ 6,721,600</u>		<u>\$ 15,472,900</u>		
Adopted replacement reserve ceiling	<u>\$ 28,785,100</u>		<u>\$ 46,161,000</u>		

See significant assumptions on page 104

VALLECITOS WATER DISTRICT

RESERVE PROJECTION FOR THE YEAR ENDING JUNE 30, 2019

	110	Water	120	210	Wastewater	220	
	<u>Replacement</u>		<u>Capacity</u>	<u>Replacement</u>		<u>Capacity</u>	<u>Total</u>
Projected July 1, 2018 Balance	\$ 27,037,300		\$ (11,422,000)	\$ 43,540,700		\$ (11,948,000)	\$ 47,208,000
Revenues and Transfers In							
Debt Proceeds	-		2,869,000	-		7,513,000	10,382,000
Operating Transfers	530,000		-	6,128,000		-	6,658,000
Capital Facility Fees	-		1,785,000	-		2,092,000	3,877,000
Property Tax	1,194,000		-	948,000		-	2,142,000
Grant Proceeds	-		-	155,000		345,000	500,000
RDA pass-through	800,000		-	800,000		-	1,600,000
Investment Earnings	143,000		(66,000)	240,000		(57,000)	260,000
Available Balance	<u>29,704,300</u>		<u>(6,834,000)</u>	<u>51,811,700</u>		<u>(2,055,000)</u>	<u>72,627,000</u>
Less 18/19 Appropriations and Transfers Out							
Encina Wastewater Authority Five Year Plan	-		-	4,702,000		1,000	4,703,000
San Marcos Interceptor	-		-	1,395,000		3,105,000	4,500,000
Meadowlark Tank No. 3	1,068,200		1,983,800	-		-	3,052,000
Montiel Gravity Outfall	-		-	1,152,000		1,408,000	2,560,000
Future Projects	1,625,000		185,000	-		-	1,810,000
High Point Pipeline	-		700,000	-		-	700,000
Las Posas 10-inch Water Main Replacement	565,000		-	-		-	565,000
N W Lake San Marcos Sewer Replacement & Relining Proj	-		-	525,000		-	525,000
Richland Invert Replacement	-		-	300,000		-	300,000
MRF: On-site Generation of Sodium Hypochlorite	-		-	300,000		-	300,000
Rock Springs Valve Replacement	220,000		-	-		-	220,000
Asset Management Replacement Schedule	100,000		-	100,000		-	200,000
District-wide Valve Replacement Program	175,000		-	-		-	175,000
Encina Parallel Land Outfall	-		-	-		150,000	150,000
Miscellaneous Projects	3,753,200		2,868,800	8,474,000		4,664,000	19,760,000
Debt Service - 2012 Debt	-		-	-		808,000	808,000
Debt Service - 2008 Loan	-		-	-		463,000	463,000
Debt Service - 2018 Issuance	-		74,800	-		196,100	270,900
Debt Service - 2015 Refunding	-		2,135,300	-		2,055,700	4,191,000
Less Total Appropriations/Transfers	<u>3,900,200</u>		<u>5,078,900</u>	<u>8,539,000</u>		<u>8,187,800</u>	<u>25,705,900</u>
Projected June 30, 2019 Balance	25,804,100		(11,912,900)	43,272,700		(10,242,800)	\$ 46,921,100
Less Operating Reserves	5,904,000		-	6,703,900		-	12,607,900
Projected replacement reserve/restricted funds	<u>\$ 19,900,100</u>		<u>\$ (11,912,900)</u>	<u>\$ 36,568,800</u>		<u>\$ (10,242,800)</u>	<u>\$ 34,313,200</u>
Adopted replacement reserve floor	<u>\$ 6,966,600</u>			<u>\$ 17,818,100</u>			
Adopted replacement reserve ceiling	<u>\$ 30,222,200</u>			<u>\$ 51,223,100</u>			

<i>Debt service coverage</i>	254%
<i>Debt service coverage without cap fees</i>	186%
<i>Debt service coverage without cap fees or property tax & RDA</i>	121%
<i>Days of Operating Expenses in Unrestricted Cash and Investments</i>	306

See significant assumptions on page 104

VALLECITOS WATER DISTRICT

RESERVE PROJECTION FOR THE YEAR ENDING JUNE 30, 2020

	110	Water	120	210	Wastewater	220	Total
	Replacement		Capacity	Replacement		Capacity	
Projected July 1, 2019 Balance	\$ 25,804,100		\$ (11,912,900)	\$ 43,272,700		\$ (10,242,800)	\$ 46,921,100
Revenues and Transfers In							
Operating Transfers	1,144,000		-	5,646,000		-	6,790,000
Capital Facility Fees	-		1,623,000	-		1,981,000	3,604,000
Property Tax	1,220,000		-	968,000		-	2,188,000
RDA pass-through	800,000		-	800,000		-	1,600,000
Debt Proceeds	-		750,000	-		1,538,000	2,288,000
Investment Earnings	294,000		(137,000)	477,000		(125,000)	509,000
Available Balance	<u>29,262,100</u>		<u>(9,676,900)</u>	<u>51,163,700</u>		<u>(6,848,800)</u>	<u>63,900,100</u>
Less 19/20 Appropriations and Transfers Out							
Encina Wastewater Authority Five Year Plan	-		-	4,660,000		136,000	4,796,000
MRF: On-site Generation of Sodium Hypochlorite	-		-	1,700,000		-	1,700,000
Montiel Gravity Outfall	-		-	738,000		902,000	1,640,000
Future Projects	1,090,000		100,000	-		-	1,190,000
Richland Invert Replacement	-		-	1,160,000		-	1,160,000
Meadowlark Tank No. 3	350,000		650,000	-		-	1,000,000
Encina Parallel Land Outfall	-		-	-		500,000	500,000
Future Projects	410,000		-	-		-	410,000
Asset Management Replacement Schedule	100,000		-	100,000		-	200,000
Miscellaneous Projects	86,100		-	68,900		1,000	156,000
Debt Service - 2012 debt	-		-	-		777,000	777,000
Debt Service - 2008 Loan	-		-	-		461,000	461,000
Debt Service - 2018	-		225,000	-		562,900	787,900
Debt Service - 2015 Refunding	-		2,137,400	-		2,057,600	4,195,000
Less Total Appropriations/Transfers	<u>2,122,200</u>		<u>3,112,400</u>	<u>8,495,800</u>		<u>5,398,500</u>	<u>19,128,900</u>
Projected June 30, 2020 Balance	27,139,900		(12,789,300)	42,667,900		(12,247,300)	\$ 44,771,200
Less Operating Reserves	<u>6,358,200</u>		<u>-</u>	<u>6,967,200</u>		<u>-</u>	<u>13,325,400</u>
Projected replacement reserve/restricted funds	\$ <u>20,781,700</u>		\$ <u>(12,789,300)</u>	\$ <u>35,700,700</u>		\$ <u>(12,247,300)</u>	\$ <u>31,445,800</u>
Adopted replacement reserve floor	\$ <u>7,448,300</u>			\$ <u>17,538,800</u>			
Adopted replacement reserve ceiling	\$ <u>31,709,600</u>			\$ <u>53,614,200</u>			

<i>Debt service coverage</i>	223%
<i>Debt service coverage without cap fees</i>	165%
<i>Debt service coverage without cap fees or property tax & RDA</i>	117%
<i>Days of Operating Expenses in Unrestricted Cash and Investments</i>	278

See significant assumptions on page 104

VALLECITOS WATER DISTRICT

RESERVE PROJECTION FOR THE YEARS ENDING JUNE 30, 2021

	110 Water 120		210 Wastewater 220		Total
	Replacement	Capacity	Replacement	Capacity	
Projected July 1, 2020 Balance	\$ 27,139,900	\$ (12,789,300)	\$ 42,667,900	\$ (12,247,300)	\$ 44,771,200
Revenues and Transfers In					
Operating Transfers	2,543,000	-	5,143,000	-	7,686,000
Capital Facility Fees	-	1,655,000	-	1,917,000	3,572,000
Property Tax	1,246,000	-	989,000	-	2,235,000
RDA pass-through	800,000	-	800,000	-	1,600,000
Debt Proceeds	-	-	-	721,000	721,000
Investment Earnings	314,000	(147,000)	496,000	(148,000)	515,000
Available Balance	<u>32,042,900</u>	<u>(11,281,300)</u>	<u>50,095,900</u>	<u>(9,757,300)</u>	<u>61,100,200</u>
Less 20/21 Appropriations and Transfers Out					
Encina Wastewater Authority Five Year Plan	-	-	3,266,000	134,000	3,400,000
Future Projects	1,205,000	-	71,100	86,900	1,363,000
Elser Lane Water Line Improvements	1,275,000	-	-	-	1,275,000
Encina Parallel Land Outfall	-	-	-	500,000	500,000
Fire Services - Backflow Preventer Upgrades	50,000	-	-	-	50,000
Chlorine Contact Tank Expansion	-	-	-	1,000	1,000
Debt Service - 2012 Debt	-	-	-	777,000	777,000
Debt Service - 2008 Loan	-	-	-	457,000	457,000
Debt Service - 2018	-	211,600	-	571,700	783,300
Debt Service - 2015 Refunding	-	2,138,900	-	2,059,100	4,198,000
Less Total Appropriations/Transfers	<u>2,530,000</u>	<u>2,350,500</u>	<u>3,337,100</u>	<u>4,586,700</u>	<u>12,804,300</u>
Projected June 30, 2021 Balance	29,512,900	(13,631,800)	46,758,800	(14,344,000)	\$ 48,295,900
Less Operating Reserves	6,898,200	-	7,276,400	-	14,174,600
Projected replacement reserve/restricted funds	<u>\$ 22,614,700</u>	<u>\$ (13,631,800)</u>	<u>\$ 39,482,400</u>	<u>\$ (14,344,000)</u>	<u>\$ 34,121,300</u>
Adopted replacement reserve floor	<u>\$ 8,327,200</u>		<u>\$ 17,601,100</u>		
Adopted replacement reserve ceiling	<u>\$ 33,281,500</u>		<u>\$ 56,250,600</u>		

<i>Debt service coverage</i>	251%
<i>Debt service coverage without cap fees</i>	194%
<i>Debt service coverage without cap fees or property tax & RDA</i>	132%
<i>Days of Operating Expenses in Unrestricted Cash and Investments</i>	283

See significant assumptions on page 104

RESERVE PROJECTION FOR THE YEAR ENDING JUNE 30, 2022

	110	Water	120	210	Wastewater	220	
	<u>Replacement</u>		<u>Capacity</u>	<u>Replacement</u>		<u>Capacity</u>	<u>Total</u>
Projected July 1, 2021 Balance	\$ 29,512,900		\$ (13,631,800)	\$ 46,758,800		\$ (14,344,000)	\$ 48,295,900
Revenues and Transfers In							
Operating Transfers	3,455,000		-	4,870,000		-	8,325,000
Capital Facility Fees	-		1,688,000	-		1,955,000	3,643,000
Property Tax	1,273,000		-	1,010,000		-	2,283,000
RDA pass-through	800,000		-	800,000		-	1,600,000
Investment Earnings	360,000		(156,000)	544,000		(198,000)	550,000
Available Balance	<u>35,400,900</u>		<u>(12,099,800)</u>	<u>53,982,800</u>		<u>(12,587,000)</u>	<u>64,696,900</u>
Less 21/22 Appropriations and Transfers Out							
Encina Parallel Land Outfall	-		-	-		3,800,000	3,800,000
Encina Wastewater Authority Five Year Plan	-		-	2,402,000		708,000	3,110,000
Future Projects	-		105,000	346,500		423,500	875,000
Chlorine Contact Tank Expansion	-		-	-		1,000	1,000
Debt Service - 2012 Debt	-		-	-		778,000	778,000
Debt Service - 2008 Loan	-		-	-		454,000	454,000
Debt Service - 2018	-		212,200	-		573,200	785,400
Debt Service - 2015 Refunding	-		2,138,400	-		2,058,600	4,197,000
Less Total Appropriations/Transfers	<u>-</u>		<u>2,455,600</u>	<u>2,748,500</u>		<u>8,796,300</u>	<u>14,000,400</u>
Projected June 30, 2022 Balance	35,400,900		(14,555,400)	51,234,300		(21,383,300)	\$ 50,696,500
Less Operating Reserves	<u>7,377,500</u>		<u>-</u>	<u>7,457,900</u>		<u>-</u>	<u>14,835,400</u>
Projected replacement reserve/restricted funds	<u>\$ 28,023,400</u>		<u>\$ (14,555,400)</u>	<u>\$ 43,776,400</u>		<u>\$ (21,383,300)</u>	<u>\$ 35,861,100</u>
Adopted replacement reserve floor	<u>\$ 9,091,900</u>			<u>\$ 18,437,700</u>			
Adopted replacement reserve ceiling	<u>\$ 35,235,400</u>			<u>\$ 59,385,900</u>			

<i>Debt service coverage</i>	264%
<i>Debt service coverage without cap fees</i>	205%
<i>Debt service coverage without cap fees or property tax & RDA</i>	143%
<i>Days of Operating Expenses in Unrestricted Cash and Investments</i>	284

See significant assumptions on page 104

LONG RANGE RESERVE PROJECTION

	2022/23	2023/24	2024/25	2025/26	2026/27
Projected Beginning Balance	\$ 50,697,000	\$ 48,680,000	\$ 47,785,000	\$ 47,254,000	\$ 47,092,000
Revenues and Transfers In					
Operating transfers	8,533,000	8,746,000	8,965,000	9,189,000	9,419,000
Capital facility fees	3,734,000	3,827,000	3,923,000	4,021,000	4,122,000
Property tax	2,332,000	2,382,000	2,433,000	2,485,000	2,538,000
Investment earnings	552,000	535,000	527,000	524,000	524,000
Capital outlay	(11,740,000)	(11,740,000)	(11,740,000)	(11,740,000)	(11,740,000)
Debt service	(5,428,000)	(4,645,000)	(4,639,000)	(4,641,000)	(4,635,000)
Projected Ending Balance	\$ 48,680,000	\$ 47,785,000	\$ 47,254,000	\$ 47,092,000	\$ 47,320,000
Operating reserves	15,206,000	15,586,000	15,976,000	16,375,000	16,784,000
Pension reserves	2,200,000	2,200,000	2,200,000	2,200,000	2,200,000
Projected replacement reserve/restricted funds	\$ 31,274,000	\$ 29,999,000	\$ 29,078,000	\$ 28,517,000	\$ 28,336,000
Adopted replacement reserve floor	\$ 28,922,000	\$ 31,160,000	\$ 33,988,000	\$ 36,468,000	\$ 37,297,000
Adopted replacement reserve ceiling	\$ 99,374,000	\$ 103,163,000	\$ 106,982,000	\$ 110,106,000	\$ 111,192,000

Significant Assumptions

Operating Transfers - the result of operating activity transferred from the disbursements fund during the year.

Tiers & Rates:

Water: Fiscal Year (FY) 17/18 will see a change in the tier structure from 4 tiers to 3 effective January 1, 2018. The tier 1 rate will increase from \$3.08 to \$3.35. The monthly ready-to-serve (RTS) for a 5/8" meter will be \$35.18 effective January 1, 2018. Assumed rate increases for FY 18/19 FY 19/20, FY 20/21 and FY 21/22 are listed below.

	2018	2019	2020	2021
Water commodity Tier 1 - Single Family Residence	\$3.35	\$3.46	\$3.65	\$3.92
Increase	\$0.09	\$0.11	\$0.19	\$0.27
Percentage Increase	2.8%	3.3%	5.5%	7.4%
	FY 18/19	FY 19/20	FY 20/21	FY 21/22
Monthly ready-to-serve 5/8" meter charge	\$35.18	\$36.78	\$38.74	\$39.99
	\$3.76	\$1.60	\$1.96	\$1.25
	11.5%	4.5%	5.3%	3.2%

Sewer: Monthly sewer for a single family residence is expected to remain at \$38.99 per month

Operating Expense Assumptions - Over the next five years, cost of wholesale water commodity will increase by 26% and wholesale fixed charges will increase 24%. Power, fuel, and chemical costs will increase by 4.5% while most other operating costs will increase by 2% from year-to-year on average. The District will add 130 water accounts in 2017/18, 120 in 2018/19, and 120 in 2019/20 and every year thereafter. The District will add 140 sewer accounts in 2017/18 through 2019/20, 130 in 2020/21 and each year thereafter.

Capital Facility Fees – The District will collect capacity charges for 160 water EDUs in fiscal years 2016/17 and 2017/18 and 150 EDUs in each fiscal year, 2018/19, 2019/20 and 2020/21. The District will collect capacity charges for 170 sewer EDUs in 2016/17 through 2018/19 and 130 sewer EDUs from 2019/20 through 2020/21. The rate per EDU will increase by 3.0% each year.

Property Tax - revenue from the 1% allocation will increase by 2.15% each year.

Investment Earnings - assumed at 1.11%.

Vallecitos Water District
 Replacement Reserve Limits - Water System
 For the 2017-18 Budget year

ENR Index (as of March 2017)	10278
------------------------------	-------

Year Added	Original Cost	ENR Factor	2016 Costs	Year of Replacement										
				2018	2019	2020	2021	2022	2023	2024	2025	2026	2027	
1957	\$ 923,038	14.20	\$ 13,103,570	422,696	422,696	422,696	422,696	422,696	422,696	422,696	422,696	422,696	422,696	422,696
1958	134,201	13.54	1,817,283	58,622	58,622	58,622	58,622	58,622	58,622	58,622	58,622	58,622	58,622	58,622
1963	2,067,687	11.41	23,586,778	760,864	760,864	760,864	760,864	760,864	760,864	760,864	760,864	760,864	760,864	760,864
1964	181,560	10.98	1,993,668	64,312	64,312	64,312	64,312	64,312	64,312	64,312	64,312	64,312	64,312	64,312
1965	256,377	10.58	2,713,741	87,540	87,540	87,540	87,540	87,540	87,540	87,540	87,540	87,540	87,540	87,540
1966	107,429	10.09	1,083,567	34,954	34,954	34,954	34,954	34,954	34,954	34,954	34,954	34,954	34,954	34,954
1967	122,039	9.57	1,167,893	37,674	37,674	37,674	37,674	37,674	37,674	37,674	37,674	37,674	37,674	37,674
1968	37,421	8.90	332,998	10,742	10,742	10,742	10,742	10,742	10,742	10,742	10,742	10,742	10,742	10,742
1969	39,742	8.10	321,882	10,383	10,383	10,383	10,383	10,383	10,383	10,383	10,383	10,383	10,383	10,383
1970	37,955	7.44	282,478	9,112	9,112	9,112	9,112	9,112	9,112	9,112	9,112	9,112	9,112	9,112
1971	90,080	6.50	585,605	18,890	18,890	18,890	18,890	18,890	18,890	18,890	18,890	18,890	18,890	18,890
1972	77,091	5.86	451,992	14,580	14,580	14,580	14,580	14,580	14,580	14,580	14,580	14,580	14,580	14,580
1973	169,427	5.42	918,929	29,643	29,643	29,643	29,643	29,643	29,643	29,643	29,643	29,643	29,643	29,643
1974	141,987	5.09	722,447	23,305	23,305	23,305	23,305	23,305	23,305	23,305	23,305	23,305	23,305	23,305
1975	230,530	4.65	1,071,152	34,553	34,553	34,553	34,553	34,553	34,553	34,553	34,553	34,553	34,553	34,553
1976	296,066	4.28	1,267,375	40,883	40,883	40,883	40,883	40,883	40,883	40,883	40,883	40,883	40,883	40,883
1977	303,133	3.99	1,209,472	39,015	39,015	39,015	39,015	39,015	39,015	39,015	39,015	39,015	39,015	39,015
1978	3,353,752	3.70	12,417,098	400,552	400,552	400,552	400,552	400,552	400,552	400,552	400,552	400,552	400,552	400,552
1979	933,794	3.42	3,195,982	103,096	103,096	103,096	103,096	103,096	103,096	103,096	103,096	103,096	103,096	103,096
1980	390,894	3.18	1,241,152	-	40,037	40,037	40,037	40,037	40,037	40,037	40,037	40,037	40,037	40,037
1981	397,944	2.91	1,157,021	-	-	37,323	37,323	37,323	37,323	37,323	37,323	37,323	37,323	37,323
1982	1,933,811	2.69	5,196,264	-	-	-	167,621	167,621	167,621	167,621	167,621	167,621	167,621	167,621
1983	3,393,243	2.53	8,577,411	-	-	-	-	276,691	276,691	276,691	276,691	276,691	276,691	276,691
1984	5,435,002	2.48	13,473,456	-	-	-	-	-	434,628	434,628	434,628	434,628	434,628	434,628
1985	675,452	2.45	1,654,898	-	-	-	-	-	-	53,384	53,384	53,384	53,384	53,384
1986	611,788	2.39	1,464,018	-	-	-	-	-	-	-	47,226	47,226	47,226	47,226
1987	799,052	2.33	1,863,971	-	-	-	-	-	-	-	-	60,128	60,128	60,128
1988	8,585,267	2.27	19,526,305	-	-	-	-	-	-	-	-	-	-	629,881
1989	1,572,104	2.23	3,501,210	-	-	-	-	-	-	-	-	-	-	-
1990	2,124,484	2.17	4,614,422	-	-	-	-	-	-	-	-	-	-	-
1991	1,777,396	2.13	3,778,299	-	-	-	-	-	-	-	-	-	-	-
1992	8,263,508	2.06	17,037,580	-	-	-	-	-	-	-	-	-	-	-
1993	3,727,844	1.97	7,354,085	-	-	-	-	-	-	-	-	-	-	-
1994	2,198,280	1.90	4,177,870	-	-	-	-	-	-	-	-	-	-	-
1995	4,438,365	1.88	8,338,058	-	-	-	-	-	-	-	-	-	-	-
1996	1,872,216	1.83	3,423,957	-	-	-	-	-	-	-	-	-	-	-
1997	3,075,659	1.76	5,425,957	-	-	-	-	-	-	-	-	-	-	-
1998	4,236,142	1.74	7,354,572	-	-	-	-	-	-	-	-	-	-	-
1999	1,216,379	1.70	2,063,367	-	-	-	-	-	-	-	-	-	-	-
2000	33,016,987	1.65	54,548,882	-	-	-	-	-	-	-	-	-	-	-
2001	1,599,452	1.62	2,591,702	-	-	-	-	-	-	-	-	-	-	-
2002	2,243,174	1.57	3,526,360	-	-	-	-	-	-	-	-	-	-	-
2003	8,148,602	1.54	12,510,207	-	-	-	-	-	-	-	-	-	-	-
2004	4,803,706	1.44	6,939,319	-	-	-	-	-	-	-	-	-	-	-
2005	4,945,039	1.38	6,825,846	-	-	-	-	-	-	-	-	-	-	-
2006	6,296,020	1.33	8,348,664	-	-	-	-	-	-	-	-	-	-	-
2007	9,123,102	1.29	11,770,932	-	-	-	-	-	-	-	-	-	-	-
2008	7,200,501	1.24	8,905,746	-	-	-	-	-	-	-	-	-	-	-
2009	32,403,360	1.20	38,861,346	-	-	-	-	-	-	-	-	-	-	-
2010	4,510,327	1.17	5,266,660	-	-	-	-	-	-	-	-	-	-	-
2011	2,053,547	1.13	2,327,051	-	-	-	-	-	-	-	-	-	-	-
2012	1,249,525	1.10	1,379,740	-	-	-	-	-	-	-	-	-	-	-
2013	3,574,225	1.09	3,884,518	-	-	-	-	-	-	-	-	-	-	-
2014	1,464,242	1.05	1,534,722	-	-	-	-	-	-	-	-	-	-	-
2015	1,950,156	1.03	1,999,379	-	-	-	-	-	-	-	-	-	-	-
2016	6,131,372	1.03	6,286,102	-	-	-	-	-	-	-	-	-	-	-
	<u>\$ 196,941,476</u>		<u>\$ 366,974,957</u>	2,201,416	2,241,454	2,278,777	2,446,398	2,723,089	3,157,717	3,211,100	3,258,327	3,318,455	3,948,336	

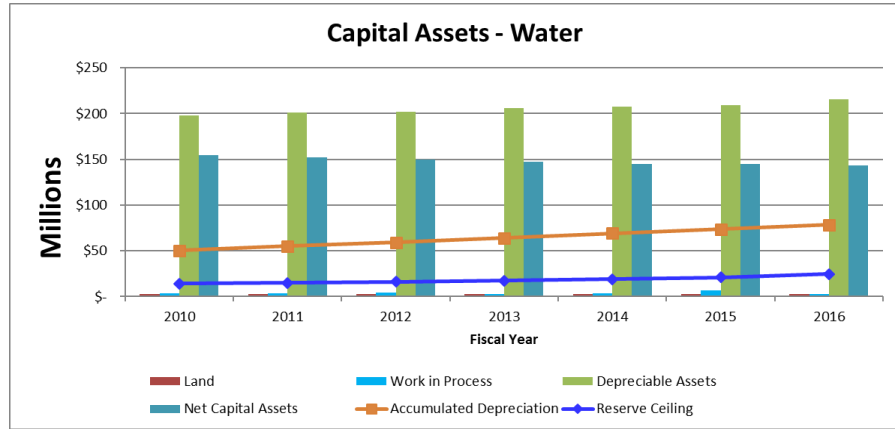

Three-Year Minimum Reserve Balance

<-----\$6,721,647----->

Ten-Year Maximum Reserve Balance

<-----\$28,785,068----->

Vallecitos Water District
 Replacement Reserve Limits - Wastewater System
 For the 2017-18 Budget year

ENR Index (as of March 2017)	10278
------------------------------	-------

Year Added	Original Cost	ENR Factor	2016 Costs	Year of Replacement											
				2018	2019	2020	2021	2022	2023	2024	2025	2026	2027		
1964	\$ 1,421,340	10.98	\$ 15,607,407	-	-	-	-	-	-	-	-	-	-	-	-
1965	394,116	10.58	4,171,704	-	-	-	-	-	-	-	-	-	-	-	-
1966	110,183	10.09	1,111,345	-	-	-	-	-	-	-	-	-	-	-	-
1967	41,816	9.57	400,172	-	-	-	-	-	-	-	-	-	-	-	-
1968	24,352	8.90	216,701	13,544	-	-	-	-	-	-	-	-	-	-	-
1969	28,784	8.10	233,130	14,571	14,571	-	-	-	-	-	-	-	-	-	-
1970	1,617,466	7.44	12,037,882	752,368	752,368	752,368	-	-	-	-	-	-	-	-	-
1971	53,601	6.50	348,457	21,779	21,779	21,779	21,779	-	-	-	-	-	-	-	-
1972	78,755	5.86	461,748	28,859	28,859	28,859	28,859	28,859	-	-	-	-	-	-	-
1973	149,279	5.42	809,651	50,603	50,603	50,603	50,603	50,603	50,603	-	-	-	-	-	-
1974	409,501	5.09	2,083,590	130,224	130,224	130,224	130,224	130,224	130,224	130,224	-	-	-	-	-
1975	189,378	4.65	879,940	54,996	54,996	54,996	54,996	54,996	54,996	54,996	54,996	-	-	-	-
1976	151,559	4.28	648,781	40,549	40,549	40,549	40,549	40,549	40,549	40,549	40,549	40,549	-	-	-
1977	394,775	3.99	1,575,115	98,445	98,445	98,445	98,445	98,445	98,445	98,445	98,445	98,445	98,445	-	-
1978	930,683	3.70	3,445,807	215,363	215,363	215,363	215,363	215,363	215,363	215,363	215,363	215,363	215,363	215,363	215,363
1979	697,184	3.42	2,386,166	149,135	149,135	149,135	149,135	149,135	149,135	149,135	149,135	149,135	149,135	149,135	149,135
1980	139,384	3.18	442,567	27,660	27,660	27,660	27,660	27,660	27,660	27,660	27,660	27,660	27,660	27,660	27,660
1981	192,586	2.91	559,943	34,996	34,996	34,996	34,996	34,996	34,996	34,996	34,996	34,996	34,996	34,996	34,996
1982	4,772,279	2.69	12,823,394	801,462	801,462	801,462	801,462	801,462	801,462	801,462	801,462	801,462	801,462	801,462	801,462
1985	5,149,309	2.45	12,616,114	788,507	788,507	788,507	788,507	788,507	788,507	788,507	788,507	788,507	788,507	788,507	788,507
1986	19,355,791	2.39	46,318,701	-	2,894,919	2,894,919	2,894,919	2,894,919	2,894,919	2,894,919	2,894,919	2,894,919	2,894,919	2,894,919	2,894,919
1987	381,136	2.33	889,087	-	-	55,568	55,568	55,568	55,568	55,568	55,568	55,568	55,568	55,568	55,568
1988	1,232,431	2.27	2,803,037	-	-	-	175,190	175,190	175,190	175,190	175,190	175,190	175,190	175,190	175,190
1989	2,001,761	2.23	4,458,093	-	-	-	-	278,631	278,631	278,631	278,631	278,631	278,631	278,631	278,631
1990	3,031,169	2.17	6,583,761	-	-	-	-	-	411,485	411,485	411,485	411,485	411,485	411,485	411,485
1991	1,864,618	2.13	3,963,711	-	-	-	-	-	-	247,732	247,732	247,732	247,732	247,732	247,732
1992	3,162,421	2.06	6,520,233	-	-	-	-	-	-	-	407,515	407,515	407,515	407,515	407,515
1993	13,446,724	1.97	26,526,954	-	-	-	-	-	-	-	-	-	1,657,935	1,657,935	1,657,935
1994	2,113,222	1.90	4,016,216	-	-	-	-	-	-	-	-	-	-	-	251,013
1995	3,276,618	1.88	6,155,562	-	-	-	-	-	-	-	-	-	-	-	-
1996	1,199,768	1.83	2,194,166	-	-	-	-	-	-	-	-	-	-	-	-
1997	988,964	1.76	1,744,691	-	-	-	-	-	-	-	-	-	-	-	-
1998	4,670,391	1.74	8,108,493	-	-	-	-	-	-	-	-	-	-	-	-
1999	1,047,495	1.70	1,776,886	-	-	-	-	-	-	-	-	-	-	-	-
2000	3,954,391	1.65	6,533,231	-	-	-	-	-	-	-	-	-	-	-	-
2001	2,705,995	1.62	4,384,710	-	-	-	-	-	-	-	-	-	-	-	-
2002	109,018	1.57	171,381	-	-	-	-	-	-	-	-	-	-	-	-
2003	9,260,829	1.54	14,217,762	-	-	-	-	-	-	-	-	-	-	-	-
2004	3,031,642	1.44	4,379,438	-	-	-	-	-	-	-	-	-	-	-	-
2005	2,984,298	1.38	4,119,352	-	-	-	-	-	-	-	-	-	-	-	-
2006	7,245,244	1.33	9,607,356	-	-	-	-	-	-	-	-	-	-	-	-
2007	(10,129,834)	1.29	(13,069,851)	-	-	-	-	-	-	-	-	-	-	-	-
2008	9,022,922	1.24	11,159,758	-	-	-	-	-	-	-	-	-	-	-	-
2009	37,476,922	1.20	44,946,068	-	-	-	-	-	-	-	-	-	-	-	-
2010	3,860,825	1.17	4,508,244	-	-	-	-	-	-	-	-	-	-	-	-
2011	1,487,477	1.13	1,685,589	-	-	-	-	-	-	-	-	-	-	-	-
2012	3,612,924	1.10	3,989,432	-	-	-	-	-	-	-	-	-	-	-	-
2013	(1,398,127)	1.08	(1,505,180)	-	-	-	-	-	-	-	-	-	-	-	-
2014	2,007,273	1.05	2,103,891	-	-	-	-	-	-	-	-	-	-	-	-
2015	(1,576,814)	1.03	(1,616,608)	-	-	-	-	-	-	-	-	-	-	-	-
2016	792,086	1.03	812,076	-	-	-	-	-	-	-	-	-	-	-	-
	<u>\$ 149,165,910</u>		<u>\$291,345,856</u>	<u>3,223,062</u>	<u>6,104,437</u>	<u>6,145,434</u>	<u>5,568,256</u>	<u>5,825,108</u>	<u>6,207,734</u>	<u>6,404,863</u>	<u>6,682,153</u>	<u>8,285,092</u>	<u>8,495,556</u>		

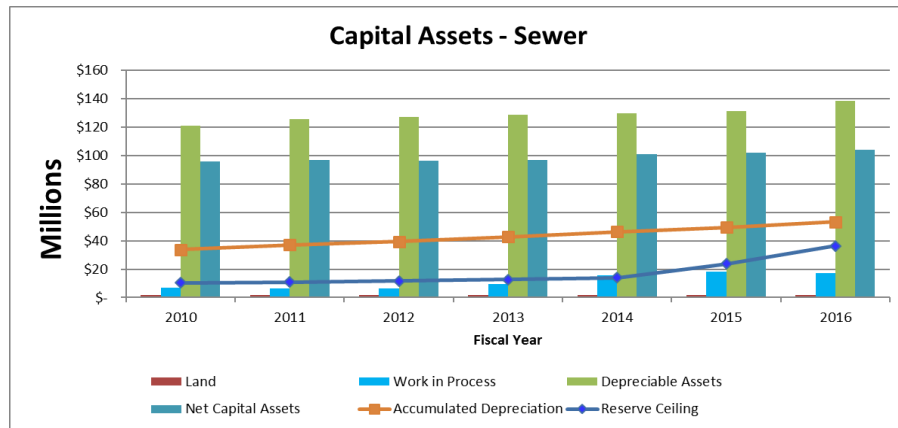

Three-Year Minimum Reserve Balance <-----\$15,472,932----->

Eight-Year Maximum Reserve Balance <----- \$46,161,047 ----->

201 Vallecitos de Oro • San Marcos, California • 92069-1453 (760) 744-0460

**NOTICE OF PUBLIC HEARING ON PROPOSED CHANGE IN
WATER AND SEWER SERVICE RATES AND WATER RATE STRUCTURE**

Date: Wednesday, August 2, 2017
Time: 5:00 p.m.
Location: 201 Vallecitos de Oro, San Marcos, CA 92069

You are receiving this notice because you are a Vallecitos Water District customer. This notice is being furnished to you pursuant to the California Constitution Article XIIIID, also known as Proposition 218. The August 2, 2017, public hearing will cover the proposed adjustments for water and sewer rates, and water rate structure to become effective from January 1, 2017, through December 31, 2019. This notice addresses why rate changes are necessary, what the water and sewer rates fund, and the basis for the proposed rates.

What is the impact to the average single family residence?

EXAMPLE

The proposed rates will result in the following increases to the average single family residential bill. Your resulting increase will vary depending on your water usage and meter size. Visit www.vwd.org/rates to learn how rates will impact you.

Average Single Family Residential Customer Bill*			
	Current	Jan 2018	Jan 2019
Total Water and Sewer Bill	\$ 118.77	\$ 123.56	\$ 128.54
\$ Increase over Prior Year		\$ 4.79	\$ 4.98
% Increase over Prior Year		4.0%	4.0%

*The average Single Family Residential Bill assumes a 5/8" meter using 13 units (9,724 gallons) of water per month.

Why are rate increases necessary?

Rate increases are necessary to continue to provide safe, reliable and sustainable water and sewer service to our customers and are required to cover the increased cost of wholesale water, electricity cost increases, inflationary cost increases, escalating costs to comply with increasingly stringent environmental regulations, replace aging infrastructure, fund an asset replacement program and meet debt service requirements.

Even with the proposed rate increases, Vallecitos is a public agency that does not operate for profit, so only those charges sufficient to support your service are billed to you. Each end user pays a fair share of the cost of water acquisition and delivery, as well as the rehabilitation, operation and maintenance of the public water and sewer facilities. As always, we will continue to honor our commitment to provide the most reliable service at the lowest possible cost.

What do water and sewer rates fund?

The proposed rates are being considered solely for the purpose of covering costs incurred by the water and sewer system, which include treated water purchases, collection and treatment of wastewater and disposal of treated effluent, water and sewer system operation and maintenance, facility and equipment maintenance, water and sewer system rehabilitation, regulatory compliance, metering, billing, and account management. The new rate structure will also be tiered to encourage conservation, fund conservation programs, comply with drought alerts and cover the costs of public awareness, education and outreach, and water reliability and diversification.

The proposed rate increases include wholesale water cost increases from our wholesaler, the San Diego County Water Authority (CWA). CWA has adopted rates for calendar years 2017 and 2018 but not for subsequent years and these wholesale rates are passed through to our customers.

What Vallecitos is doing to control costs?

Vallecitos' priority to ensure financial stability is to control costs. In recent years Vallecitos has restructured its organization, eliminating positions, and redistributing workload to maximize productivity and efficiency. The last two labor negotiations have resulted in cuts to employee benefits. Vallecitos contracted with the Olivenhain Municipal Water District for water treatment services at a cost of 20% less than the San Diego County Water Authority's treatment charge. Vallecitos has engaged consultants to perform energy and operational efficiency studies and implemented recommendations from the studies, as well as input from staff, including changes and upgrades to the sewer treatment process which reduced chemical usage and power consumption, installing energy efficient lighting and pumping equipment, in-house mechanical and fleet maintenance, critical asset condition assessments, predictive asset maintenance and replacement, and strategic use of technology throughout field operations and customer billing. Staff evaluates the effectiveness of changes implemented and continuously improves efficiency of operations.

How are water and sewer rates determined?

A comprehensive Cost of Service Study was performed. One of the major goals of the study was to ensure equitable water and sewer rates that produce adequate revenues to meet the District's financial needs, recognize customer costs of service and encourage water conservation in a resource-constricted environment. No increase to sewer rates are being proposed. For more information, the report is posted to www.vwd.org.

How to provide comments or protest the rate adjustment

You may comment or ask questions at any time by contacting Vallecitos Water District, 760.744.0460, vwd@vwd.org, or participating in the August 2, 2017, Public Hearing at 5:00 pm.

You have the right to protest the rate change if you are:

- i. The record owner of an affected parcel,
- ii. A person with a legal interest in an affected parcel, or
- iii. A person who is legally responsible to pay the rates for an affected parcel.

User rates are subject to majority protest, which means if a majority of impacted owners submit written protest against the increase, Vallecitos Water District cannot institute the new rates.

Protests must be in writing and mailed or hand-delivered to Vallecitos Water District. In accordance with State law, faxed or e-mailed protests cannot be accepted.

In compliance with Proposition 218, only one protest per property will be counted. All written protests must be received by Vallecitos Water District before the end of the Public Hearing on August 2, 2017. Please direct written protests to Vallecitos Water District, General Manager, 201 Vallecitos de Oro, San Marcos CA 92069.

Water Monthly Ready-to-Serve Charges			
Meter Size	Current	Effective January:	
		2018	2019
5/8"	\$ 31.42	\$ 34.02	\$ 36.00
3/4"	36.52	36.52	36.52
1"	55.29	55.29	55.29
1.5"	110.59	121.59	132.59
2"	178.11	195.91	219.10
3"	356.22	356.22	356.22
4"	552.94	552.94	552.94
6"	1,105.88	1,105.88	1,105.88
10"	2,549.36	2,549.36	2,549.36
Multiple Dwelling Unit	18.26	14.54	14.54
Temporary Meters	204.48	233.27	262.05
Fire Line per diameter inch	5.87	5.87	5.87

The monthly **Ready-to-Serve Charge** is assessed to recover fixed charges paid by the District to the District's wholesaler, San Diego County Water Authority, expenses associated with meters and service lines, operating expenses not directly related to the flow of water (general and administrative, engineering, information technology, etc.), and capital asset replacement costs of service lines, meters, and general facilities. These expenses are incurred by the District even if no water is delivered to our customers.

Water Commodity Tier Structure in Units (748 gallons)							
Meter Size	Current				Effective January 2018		
	Tier 1	Tier 2	Tier 3	Tier 4	Tier 1	Tier 2	Tier 3
<1"	1 - 5	6 - 17	18 - 36	37 +	1 - 6	7 - 21	22 +
1"	1 - 5	6 - 60	61 - 214	215 +	1 - 16	17 - 78	79 +
1.5"	1 - 5	6 - 157	158 - 627	628 +	1 - 43	44 - 196	197 +
2"	1 - 5	6 - 242	243 - 806	807 +	1 - 85	86 - 335	336 +
>2"	1 - 5	6 - 1133	1134-3970	3,971 +	1 - 430	431-1,190	1,191 +
Agricultural	1 - 5	6 +				1 +	
Temporary Construction				1 +			1 +

Water Commodity Rates per Unit			
	Current	Effective January:	
		2018	2019
Tier 1	\$ 3.08	\$ 3.35	\$ 3.64
Tier 2	4.12	4.35	4.53
Tier 3	5.33	8.30	8.73
Tier 4	7.41		

Water Commodity Rates recover the cost of water supply, expenses directly associated with water flow (transmission and distribution, water treatment, tanks and reservoirs, etc.), conservation costs, and capital replacement costs of assets directly associated with water flow (tanks and reservoirs, transmission and distribution, pumping, etc.).

Sewer Monthly Service Charges			
Customer Type	Current	Effective January:	
		2018	2019
Single Family Residential	\$ 38.99	\$ 38.99	\$ 38.99
Residential - Multiple Unit	35.09	35.09	35.09
Mobile Home	31.19	31.19	31.19
Nonresidential <i>(per 100 cubic feet of flow)</i>	4.96	4.96	4.96

Sewer Service Charges recover costs of capital replacement of sewer system assets and general facilities, disposal, collection and conveyance, sewer treatment, and operations (general and administrative, information technology, engineering, etc.).

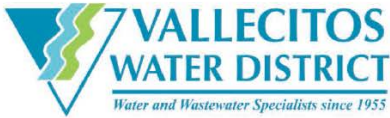

PRSR STD
 US POSTAGE
 PAID
 SAN DIEGO CA
 PERMIT 906

This legal notice contains important information regarding rates associated with providing 21,000 plus customers in San Marcos, portions of Carlsbad, Escondido, Vista and unincorporated areas in San Diego County with safe, reliable water and wastewater services. (Para información en Español, visítenos en www.vwd.org o llámenos a (760)744-0460.)



Notice of Public Rate Hearing

Conservation Assistance

To assist customers to conserve water and reduce their water bill, Vallecitos offers free landscape irrigation audits to determine the efficiency of your irrigation system. For more information on water conservation programs, please visit our website at www.vwd.org/conservation or go to SustainableLandscapesSD.org.

SUSTAINABLE LANDSCAPES PROGRAM

- Guidelines
- Education & Training
- Technical Assistance
- Landscape Materials
- Incentives
- Resources

"Like us" on Facebook or follow us on Twitter@vallecitoswater www.vwd.org | 760.744.0460