

**EASEMENT ROAD DETAIL**  
NOT TO SCALE

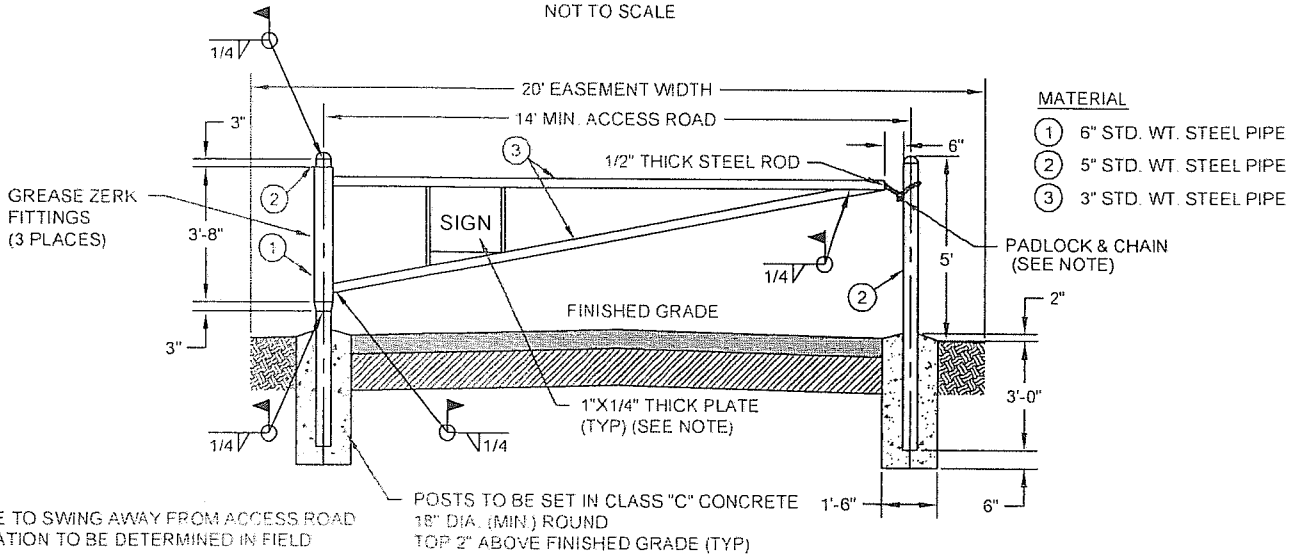
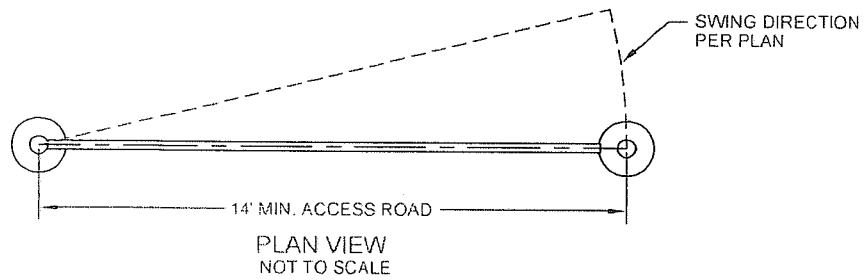

**NOTES:**

1. GATE TO SWING AWAY FROM ACCESS ROAD LOCATION TO BE DETERMINED IN FIELD
2. PADLOCK AND SIGN TO BE FURNISHED BY DISTRICT.
3. PAINT PER SPECIFICATIONS

POSTS TO BE SET IN CLASS "C" CONCRETE 18" DIA. (MIN.) ROUND TOP 2" ABOVE FINISHED GRADE (TYP)

**FRONT VIEW**  
NOT TO SCALE

**NON-RESIDENTIAL GATE DETAIL**

**RESIDENTIAL GATES**

1. RESIDENTIAL GATES SHALL BE DOUBLE GATE.
2. TOTAL WIDTH SHALL BE 14' MINIMUM.
3. STYLE TO BE BY HOMEOWNER OR MATCH EXISTING FENCING.
4. LOCK TO BE PROVIDED BY HOMEOWNER.
5. DISTRICT SHALL BE PROVIDED ACCESS AS NECESSARY.

REVISIONS			VALLECITOS WATER DISTRICT STANDARD DRAWING	DATE:
DESCRIPTION	APPROVED	DATE		BY:
			<b>WATER/SEWER EASEMENT ROAD AND GATE DETAILS</b>	DRAWING NO.