

NOTES:

- 1) ALL FLANGES TO BE WELDED IN FIELD, PER A.W.W.A. C-207.
- 2) ALL STEEL PIPE, FIELD WELDING' AND REPAIRS, SHALL BE PER A.W.W.A. C-205 & C-206.
- 3) INSTALL HANDHOLE W/ PLUG MIN. OF 6" FROM EACH WELDED JOINT, DETAIL "A"

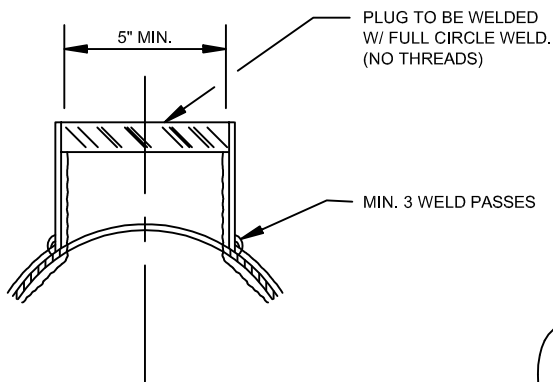

DETAIL "A"
(HANDHOLE)

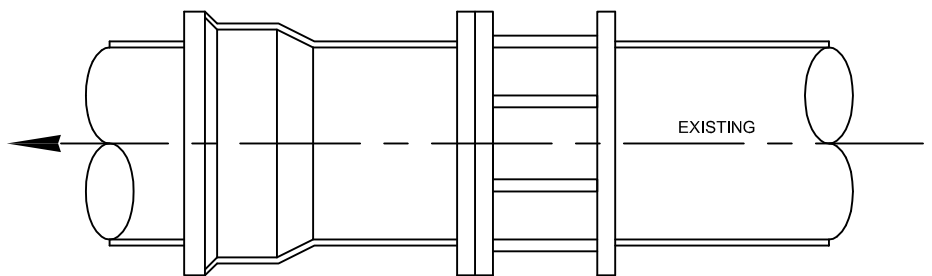

DETAIL "B"
(P.O. x FLG ADAPTER)

REVISIONS			VALLECITOS WATER DISTRICT STANDARD DRAWING	DATE: JAN. 04
DESCRIPTION	APPROVED	DATE		BY:
			UTILITY CROSSING (STEEL WATER PIPE)	Drawing No.
				W-27